

INDUSTRIAL AUTOMATION

USER MANUAL

Manuale d'uso

Manuel d'emploi

Bedienungsanleitung

Manual de uso

Manual do usuário

Руководство по эксплуатации

VARIABLE FREQUENCY DRIVE **SINUS VEGA** Basic User Manual-Manuale d'uso Basic

Contents

1 Preface.....	4
2 Inspection	5
3 Safety precautions	6
3.1 Safety definition	6
3.2 Safety items	6
3.3 Notice Items.....	9
4 Specifications and Optional Parts	12
4.1 Technical specifications.....	12
4.2 Products Series Introduction.....	14
4.2.1 SINUS VEGA Models.....	14
4.2.2 Ordering information of SINUS VEGA series	15
4.2.3 Size	16
4.2.4 Protective cover	18
4.2.5 LED Keypad Display Unit Size	18
4.2.6 Optional Parts	19
4.2.7 Braking Resistor and Recommendation of Braking Unit.....	19
5 Installation and wiring	22
5.1 Installation	22
5.1.1 EMC Compliance Installation.....	23
5.1.2 Noise Suppression	25

5.1.3 Using Surge Suppressor.....	26
5.1.4 Leakage Current.....	27
5.1.5 Applications of Power Filter.....	28
5.1.6 AC Line Reactor Applications.....	28
5.2 Wiring.....	29
5.2.1 Overview.....	30
5.2.2 Power Terminals.....	31
5.2.3 Control Circuit Wiring.....	33
5.2.4 Onsite Wiring Requirements.....	42
5.2.5 Earthing.....	43
6. Operation Procedures.....	45
6.1 AC Drive Operation Panel.....	45
7 Description of Function Codes.....	47
7.1 Group F0: Basic Parameters.....	47
7.2 Group F1: Motor 1 Parameters.....	60
7.3 Group F2: Vector Control Parameters.....	65
7.4 Group F3: V/F Control Parameters.....	69
7.5 Group F4: Input Terminals.....	75
7.6 Group F5: Output Terminals.....	89
7.7 Group F6 Start/Stop Control.....	94
7.8 Group F7 Operation Panel and Display.....	101

7.9 Group F8 Auxiliary Functions.....	105
7.10 Group F9 Fault and Protection.....	116
7.11 Group FA: Process Control PID Function.....	125
7.12 Group FB: Swing Frequency, Fixed Length and Count.....	132
7.13 Group FC: Multi-Reference and Simple PLC Function.....	135
7.14 Group FD: Communication Parameters.....	141
7.15 Group FP: User's Password.....	141
7.16 Group A0: Torque Control and Restricting Parameters.....	144
7.17 Group A2 to A4: Motor 2 to Motor 4 Parameters.....	145
7.18 Group U0 Monitor.....	149
8. Parameters.....	152
9 Maintenance and Troubleshooting.....	183
9.1 Routine Repair and Maintenance of the SINUS VEGA.....	183
9.1.1 Routine Maintenance.....	183
9.1.2 Periodic Inspection.....	183
9.1.3 Replacement of Vulnerable Components.....	184
9.1.4 Storage of the AC Drive.....	184
9.2 Warranty Agreement.....	184
9.3 Faults and Solutions.....	185
9.4 Common Faults and Solutions.....	189
10 Modbus communication.....	192

1 Preface

Thank you for using SINUS VEGA series inverter made by SANTERNO

SINUS VEGA series satisfies high performance requirements by using a unique control method to achieve high torque, high accuracy and wide speed-adjusting range. Its anti-tripping function and capabilities of adapting severe power network, temperature, humidity, and dusty environment exceeds those of similar products made by other companies, which improves the products reliability noticeably.

SINUS VEGA considers customers' needs and combines general purpose function and industrial-oriented function. It features PI control, simple PLC, flexible I/O terminals and pulse frequency setting. You can select whether to save the parameters upon power off or stop, bind frequency setting channel with command channel, zero frequency return difference zero frequency hysteresis, main and auxiliary frequency setting, traverse operation, length control, etc. It is an integral, cost-effective and highly reliable solution for manufacture in the related fields.

SINUS VEGA series can satisfy the customers' requirements on low noise and EMI by using optimized PWM technology and EMC design.

This manual provides information on installation, wiring, parameters setting, trouble-shooting, and routine maintenance. In order to ensure the correct installation and operation of the inverter, please read this manual carefully before using and keep it in a safe place. (V1.0)

2 Inspection

Don't install or use any inverter that is damaged or have fault parts otherwise may cause injury.

Check the following items when unpacking the inverter.

1. Ensure there is operation manual and warranty cards in the packing box.
2. Inspect the entire exterior of inverter to ensure there are no scratches or other damaged caused by transportation.
3. Check the nameplate and ensure it is what you ordered.
4. Ensure the optional parts are what you need if you have ordered any optional parts.

Please contact the local agent if there is any damage in the inverter or the optional parts.

3 Safety precautions

3.1 Safety definition

In this manual, the safety precautions are sorted to “Danger” or “Caution”



Operations without following instructions can cause personal injury or death.



Operation without following instructions can cause personal injury or damage to product or other equipment.

3.2 Safety items

Before installation:



1. Please don't use the inverter of being scathed or loss of parts!
2. Please use the insulating motor upwards B class; otherwise it will result in death or serious injury on account of getting an electric shock!

When installation:



Please install the inverter on the fireproofing material (such as metal) to prevent fire!



1. When you need to install two or more inverters in one cabinet, cooling fans should be provided to make sure that the ambient temperature is lower than 45°C. Otherwise it could cause fire or damage to the device.
2. No wires head or screws fall into the inverter!

When wiring:



1. Only qualified personnel shall wire the inverter!
2. Inverter and power must be comparted by the breaker; otherwise the fire will be caused!
3. Never wire the inverter unless the input AC is totally disconnected!
4. The ground terminal must be properly earthed to reduce electrical accident!



1. Connect input terminals(R,S,T) and output terminals(U,V,W) correctly. Otherwise it will cause damage the inside part of inverter!
2. Make sure that the wring according with EMC requirements and safety standards in the region, the wire diameter used reference the manual suggested; otherwise it will cause an accident!
3. Brake resistor cannot be directly connected between “DC bus+” and “DC bus-” terminals, or it may cause a fire!

Before power-on:



1. Please confirm whether the power and voltage level is consistent with the rated voltage of the inverter, input and output wiring position is correct or not, and pay attention to check whether there are short-circuit in the external circuit phenomenon, ensure the line is fastened. Otherwise the inverter may cause damage!
2. Install the cover before power-on, in order to reduce the danger of electric shock!



1. Inverters do not need to do pressure test, factory products have made this test, and otherwise it may cause an accident!
2. All the external parts are connected exactly in accordance with this manual, or it may cause an accident!

After power-on:



1. Do not open the cover after power-on, otherwise there is a risk of electric shock!
2. Do not wire and operate the inverter with wet hands, otherwise there is a risk of electric shock!
3. Do not touch inverter terminals (including the control terminals), otherwise there is a risk of electric shock!
4. At the beginning of power-on, the inverter can carry out safety testing for external strong electric circuit automatically, at this time, please do not touch U,V,W terminals or motor terminals, otherwise there is a risk of electric shock!



1. If you need parameter identification, please note that the risk of injuries in motor rotation, otherwise it may cause an accident!
2. Please do not arbitrarily change the parameters of inverter manufactures; otherwise it may result in equipment damage!

Operating status:



1. When the user selects the function re-starting, please do not stay close to the mechanical equipment, otherwise it may cause personal injury!
2. Do not touch the radiator, otherwise it may cause burn !
3. Only qualified personnel shall detect the signal, otherwise it may cause personal injury or equipment damage!



1. When the inverter is running, please avoid the sundries fall into the device, otherwise it would cause equipment damage!
2. Please do not use the method of contactor on and off to control the inverter's start-stop,

otherwise it would cause equipment damage!

When maintaining:



1. Never service and maintain inverter with electrification, otherwise it may cause injury or electric shock!
2. Ensure the inverter's "CHARGE" light turns off before the maintenance and repair of the inverter, otherwise the residual charge on the capacitor may cause personal injury!
3. Only trained personnel shall operate and maintain this equipment, otherwise it will cause personal injury or equipment damage!

3.3 Notice Items

1. Insulation of Motors

Before using the inverter, the insulation of motors must be checked, especially, if it is used for the first time or if it has been stored for a long time. This is to reduce the risk of the inverter from being damaged by the poor insulation of the motor winding. Please use 500V insulation tester to measure the insulation resistance. It should not be less 5MΩ.

2. Thermal protection of the motor

If the selection of motor and rated capacity of the inverter does not match, especially when rated power of the inverter is greater than rated power of the motor, be sure to adjust the motor protection-related parameters in the inverter or pre-installed in the motor thermal relay for motor protection.

3. Working above power frequency

The inverter can provide 0Hz-320Hz output frequency, if the customers need to run at 50Hz or above, please consider the affordability of mechanical devices.

4. The vibration of mechanical devices

When the output frequency to achieve certain values of the inverter, you may encounter a mechanical resonance point of the load devices. It can be avoided by setting the parameters

of the frequency jump in inverter.

5. Regarding motor heat and noise

Because the output voltage of the inverter is the PWM wave, it contains some harmonics wave. Therefore, there will be some increase in temperature, noise, vibration in motor and Work-frequency.

6. Varistors for Surge Protection or Capacity Used to improve the Power Factor

Don't connect any varistors or capacitors to the output terminals of the inverter. Because the inverter's output voltage waveform is pulse wave, otherwise, it may cause tripping or damage to components.

7. If circuit breaker or contactor needs to be connected between the inverter and the motor, be sure to operate these circuit breakers or contactor when the inverter has no output to avoid damaging of the inverter. Otherwise it may cause damage to the inverter module.

8. Using outside rated voltage

The inverter is not suitable to be used out of the specified range of operating voltage. If needed, please use suitable voltage regulation device.

9. Three-phase input change to Two-phase input

Don't permit of changing three-phase inverter as two-phase to be used, or it will result in failure or damage to inverter.

10. Protection against lightning strike

There are transient surge suppressors inside the inverter that protect it against lightning strike.

11. Derating due to Altitude

Derating must be considered when the inverter is installed at high altitude, greater than 1000m. This is because the cooling effect of the inverter is less effective in the thin air. If the motor cable is greater than 100 m long, an AC output reactor must be installed close to the AC drive. For details, please contact us.

12. Some special usages

If the customers need to use the wiring diagram that the manual did not mention , such as the common DC bus, please contact us.

13. Disposing Unwanted inverters

- 1) The capacitors may explode when they are burnt.
- 2) Poisonous gas may be generated when the plastic parts like front covers are burns.
- 3) Please dispose the inverter as industrial waste.

14. Adaptive motor

1) Standard adaptive motor for 4 grade Squirrel-cage asynchronous induction motor. If it is not above motor that may select the inverter according to rated current of motor. If you need to inverter permanent magnet synchronous motor, please ask for support.

2) The cooling fan of non-inverter motor and the rotor axis is a coaxial connection,the effect of fan cooling is poor when the speed decreases, therefore, should be retrofitted with exhaust fan or replace for the inverter motor in the motor overheat occasion.

3) The inverter has built-in standard parameters of adaptive motor, according to the actual situation ,Motor parameter identification needs to be done or personality default value in order to be compatible with the actual value,otherwise it will affect the running results and protection performance.

4) If the short-circuit occurred in the cable or the internal motor will cause the inverter alarm, and even deep-fried machine. When the motor and cable just installed, please first conduct insulation short-circuit tests, routine maintenance is also required to conduct this test regularly.

Before using, please read this manual thoroughly to ensure proper usage. Keep this manual at an easily accessible place so that can refer anytime as necessary.

4 Specifications and Optional Parts

4.1 Technical specifications

Figure 4-1 Technical specifications of the SINUS VEGA

Item		Specifications
Standard functions	Maximum frequency	Vector control: 0–300 Hz/V/F control: 0–320 Hz
	Carrier Frequency	0.5–16 kHz The carrier frequency is automatically adjusted based on the load features.
	Input frequency Resolution	Digital setting: 0.01 Hz Analog setting: maximum frequency x 0.025%
	Control mode	Sensorless flux vector control (SVC) Closed-loop vector control (FVC) Voltage/Frequency (V/F) control
	Startup torque	HEAVY DUTY: 0.5 Hz/150% (SVC); 0 Hz/180% (FVC) NORMAL DUTY: 0.5 Hz/100%
	Speed range	1:100 (SVC) 1:1000 (FVC)
	Speed stability Accuracy	±0.5% (SVC) ±0.02% (FVC)
	Torque control Accuracy	±5% (FVC)
	Overload capacity	HEAVY DUTY: 60s or 150% of the rated current, 3s for 180% of the rated current NORMAL DUTY: 60s for 120% of the rated current, 3s for 150% of the rated current
	Torque boost	Fixed boost Customized boost 0.1%–30.0%
	V/F curve	Straight-line V/F curve Multi-point V/F curve N-power V/F curve (1.2-power, 1.4-power, 1.6-power, 1.8-power, square)
	V/F separation	Two types: complete separation; half separation
	Ramp mode	Straight-line ramp S-curve ramp Four groups of acceleration/deceleration time with the range of 0.0–6500.0s
	DC braking	DC braking frequency: 0.00 Hz to maximum frequency Braking time: 0.0–36.0s Braking action current value: 0.0%–100.0%
	JOG control	JOG frequency range: 0.00–50.00 Hz JOG acceleration/deceleration time: 0.0–6500.0s
	Onboard multiple preset speeds	It implements up to 16 speeds via the simple PLC function or combination of X terminal states.
Onboard PID	It realizes process-controlled closed loop control system easily.	

Item		Specifications
	Auto voltage regulation (AVR)	It can keep constant output voltage automatically when the mains voltage changes.
	Over voltage/ Over current stall Control	The current and voltage are limited automatically during the running process so as to avoid frequent tripping due to over voltage/over current.
	Fast current limiting function	Minimizing over-current fault protect the normal operation of the inverter
	Torque limit and control	It can limit the torque automatically and prevent frequent over current tripping during the running process. Torque control can be implemented in the SVC and FVC mode.
Individualized functions	High performance	Control of asynchronous motor and synchronous motor are implemented through the high-performance current vector control technology.
	Power dip ride Through	The load feedback energy compensates the voltage reduction so that the AC drive can continue to run for a short time.
	Rapid current limit	It helps to avoid frequent over current faults of the AC drive.
	Virtual I/Os	Five groups of virtual X/Dos can realize simple logic control.
	Timing control	Time range: 0.0–6500.0 minutes
	Multi-motor switchover	Four motors can be switched over via four groups of motor parameters.
	Multiple communication Protocols	It supports communication via Modbus –RTU.
RUN	Running command source	Operation panel Control terminals Serial communication port You can perform switchover between these sources in various ways.
	Frequency source	There are a total of 10 frequency sources, such as digital setting, analog voltage setting, analog current setting, pulse setting and serial communication port setting. You can perform switchover between these sources in various ways.
	Auxiliary frequency source	There are ten auxiliary frequency sources. It can implement fine tuning of auxiliary frequency and frequency synthesis.
	Input terminal	Standard: 7 digital input (X) terminals, one of which supports up to 100 kHz high-speed pulse input 2 analog input (AI) terminals, one of which only supports 0–10 V voltage input and the other supports 0–10 V voltage input or 0–20 m A current input

Item		Specifications
	Output terminal	Standard 1 high-speed pulse output terminal (open-collector) that supports 0–100 kHz square wave signal output 1 digital output (DO) terminal 2 relay output terminal 2 analog output (AO) terminal that supports 0–20 m A current output or 0–10 V voltage output
Display and operation on the operation panel	LED display	It displays the parameters.
	Key locking and function selection	It can lock the keys partially or completely and define the function range of some keys so as to prevent mis-function.
	Protection mode	Motor short-circuit detection at power-on, input/output phase loss protection, over current protection, over voltage protection, under voltage protection, overheat protection and overload protection
Environment	Installation Location	Indoor, free from direct sunlight, dust, corrosive gas, combustible gas, oil smoke, vapour, drip or salt.
	Altitude	Lower than 1000 m
	Ambient Temperature	-10°C to +40°C (de-rated if the ambient temperature is between 40°C and 50°C)
	Humidity	Less than 95%RH, without condensing
	Vibration	Less than 5.9 m/s ² (0.6 g)
	Storage Temperature	- 20°C ~ + 60°C
	IP level	IP20
	Pollution degree	PD2
	Power distribution System	TN , TT

4.2 Products Series Introduction

4.2.1 SINUS VEGA Models

Table4-1 Inverter series

Size	Model	Inom	Imax	Applicable motorpower			Applicable motorpower		
				<i>NORMAL DUTY</i>			<i>HEAVY DUTY</i>		
				kW	H	A	kW	H	A
K01	SINUS VEGA 0005 4T	9	14	4	5.5	9	4	5.5	9
K10	SINUS VEGA 0007 4T	17	20	7.5	10	17	5.5	7.5	13

Size	Model	Inom	Imax	Applicable motorpower			Applicable motorpower		
				NORMAL DUTY			HEAVY DUTY		
				kW	H	A	kW	H	A
K10	SINUS VEGA 0011 4T	25	26	11	15	25	7.5	10	17
K15	SINUS VEGA 0015 4T	32	38	15	20	32	11	15	25
K15	SINUS VEGA 0018 4T	37	48	18.5	25	37	15	20	32
K40	SINUS VEGA 0022 4T	45	56	22	30	45	18.5	25	37
K40	SINUS VEGA 0030 4T	60	68	30	40	60	22	30	45
K45	SINUS VEGA 0037 4T	75	90	37	50	75	30	40	60
K45	SINUS VEGA 0045 4T	90	113	45	60	90	37	50	75
K50	SINUS VEGA 0055 4T	110	135	55	75	110	45	60	90
K50	SINUS VEGA 0075 4T	152	165	75	100	152	55	75	110
K50	SINUS VEGA 0090 4T	176	228	90	125	176	75	100	152
K55	SINUS VEGA 0110 4T	210	264	110	150	210	90	125	176
K55	SINUS VEGA 0132 4T	260	315	132	180	260	110	150	210
K55	SINUS VEGA 0160 4T	305	390	160	220	305	132	180	260

NORMAL DUTY: Overload 120% rated current for 1 minute- for applications which use self-ventilated induction motors and require a low overload capability (e.g. fans, pumps)

HEAVY DUTY: Overload 150% rated current for 1 minute- Overload 180% rated current for 3 Sec Overload 200% rated current for 0.5 Sec. for constant torque applications which require a high overload capability (e.g. cranes, hoists)

4.2.2 Ordering information of SINUS VEGA series

Please refer to Figure4-2 and Figure4-3.

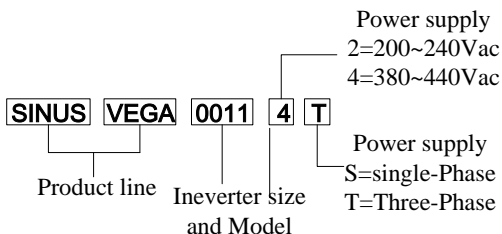

Table 4-2 Explanations of inverter models



SINUS VEGA0011 4T	
INPUT : AC3PH380~440V+10/-15% 50/60Hz	
OUTPUT : AC3PH0~440V0 ~ 320 Hz	
Normal Duty : 11kW/15HP/25A	
Heavy Duty : 7.5kW/10HP/17A	
K10/IP20/Imax:26A/Inom:25A	
	 
Via della Concia 7, 40023 Castel Guelfo (BO) Italy	
www.santerno.com	
Made in P.R.C	
S/N	

Table 4-3 SINUS VEGA series nameplate

4.2.3 Size

Please refer to Figure 4-4 and Table 4-2.



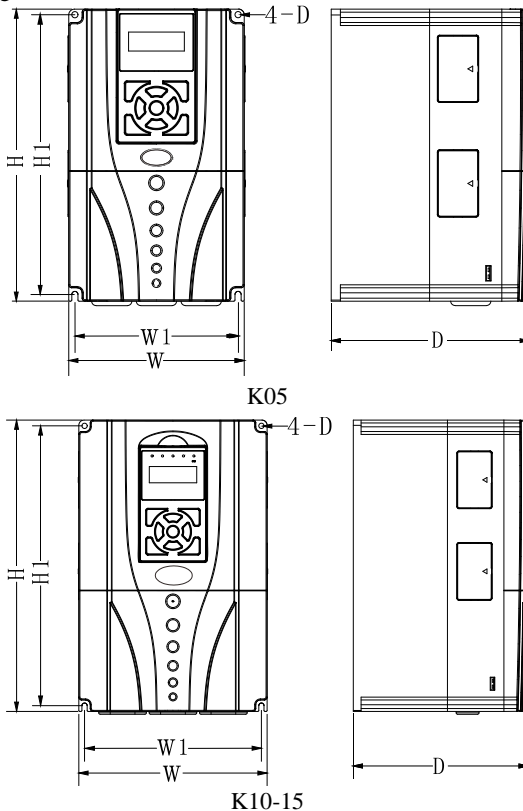
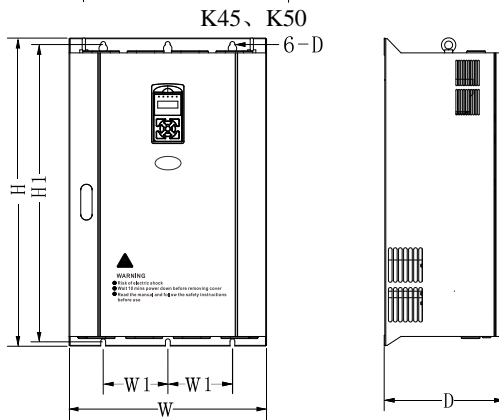
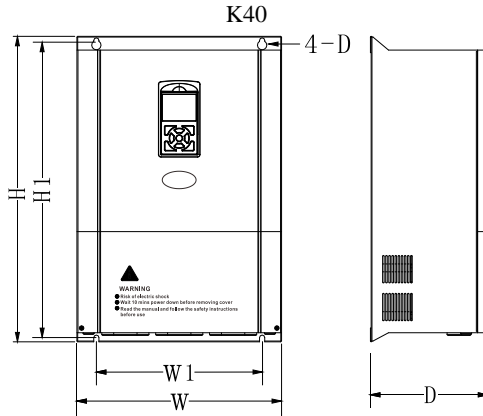
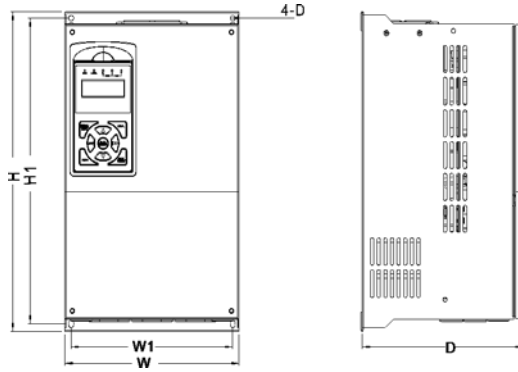

K55

Figure 4-4 SINUS VEGA series inverter size

Table 4-2 Dimensions of SINUS VEGA series (mm)

Size	Model	W (mm)	H (mm)	Mounting hole	D (mm)	Weight (kg)
K05	SINUS VEGA 0005 4T	140	215	5.5	175	3.6
K10	SINUS VEGA 0007 4T~ SINUS VEGA 0011 4T	157	262	5.5	181	5
K15	SINUS VEGA 0015 4T~ SINUS VEGA 0018 4T	198	305	5.5	188	7
K40	SINUS VEGA 0022 4T~ SINUS VEGA 0030 4T	210	350	6	194	12
K45	SINUS VEGA 0037 4T~ SINUS VEGA 0045 4T	276	438	7	220	18.5
K50	SINUS VEGA 0055 4T~ SINUS VEGA 0090 4T	325	570	10	280	41.5
K55	SINUS VEGA 0110 4T~ SINUS VEGA 0160 4T	489	759	12	298	85

4.2.4 Protective cover



Notice: For ventilation, try not to use protective cover, unless there is a need, so that you can extend the inverter's life.

4.2.5 LED Keypad Display Unit Size

Through it, operation and configuration of the inverter can be done. Please refer to its size and configuration in Figure 4-5.

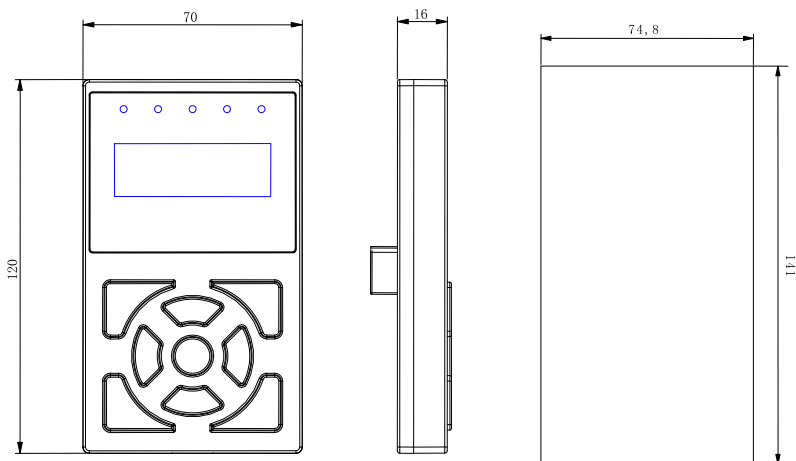

Keypad dimensions of SINUS VEGA 0005 4T~ 0160 4T

Figure 4-5 Keypad display unit

4.2.6 Optional Parts

You may order the optional parts below from our company.

Part name	Applicable range	Specification	Remarks
Braking resistor	Pls refer to tale 4-3	Pls refer to table 4-3	
Keypad connect board	0.4KW~4.0KW optional	-	Ethernet connection will be enabled
Keypad tray	Above 5.5KW optional	74.7×141	dimension
Keypad extension cable	4KW~160KW optional	2m、3m	Internet cable;
Basement	132KW~160KW optional	539*370*485	132KWbasement is applicable for both cabin it and wall type interers
Direct current reactor	132KW~160KW optional	-	-

4.2.7 Braking Resistor and Recommendation of Braking Unit

SINUS VEGA series inverter is equipped with braking unit. If there is a need for energy-consuming braking, please select a braking resistor in Table4-3; please refer the wiring of

braking resistor and the inverter to Figure5-2. The wire specifications are listed in Table4-3.

Table4-3 Braking Resistor and Recommendation of Braking Unit

Size	Model	Suggested value of resistance	Suggested power	Suggested model of braking unit	Remark
K05	SINUS VEGA 0005 4T	100-150Ω	300W	Built-in standard parts	Match Proper Motor
K10	SINUS VEGA 0007 4T	80-100Ω	500W		
K10	SINUS VEGA 0011 4T	60-80Ω	700W		
K15	SINUS VEGA 0015 4T	40-50Ω	1KW		
K15	SINUS VEGA 0018 4T	30-40Ω	1.5KW		
K40	SINUS VEGA 0022 4T	25-30Ω	2KW		
K40	SINUS VEGA 0030 4T	20-25Ω	2.5KW		
K45	SINUS VEGA 0037 4T	15-20Ω	3KW	Built-in optional parts	Add “B” at the end of model
K45	SINUS VEGA 0045 4T	15-20Ω	3.5KW		
K50	SINUS VEGA 0055 4T	10-15Ω	4.5KW		
K50	SINUS VEGA 0075 4T	10-15Ω	5.5KW		
K50	SINUS VEGA 0090 4T	8~10Ω	7.5 KW	BU4R150	optional parts
K55	SINUS VEGA 0110 4T	8~10Ω	9 .0KW		
K55	SINUS VEGA 0132 4T	6~8Ω	11 .0KW		
K55	SINUS VEGA 0160 4T	6~8Ω	13.5KW	BU4R250	optional parts

P.S: the calculation method of braking resistance:

When braking is enabled, almost all renewable energy have been consumed by the braking resistor, please follow the following formula:

$$U \times U / R = P_b$$

In this formula: U means the braking voltage of the system(The value of U may differ from each system, I.e, 380Vac system, U is 700V generally.

P_b is the braking power

Power selection for braking resistor

Theoretically, the braking resistor’s power is the same as the braking power, however by taking the 70% derate into consideration, you can use the following formula to calculate the braking

resistor's power:

$$0.7 \times P_r = P_b \times D$$

P_r --power of the braking resistor

D --braking frequency

Braking frequency values for standard elevator and winder applications:

Applications	Elevator	Winding and unwinding	Centrifuge machine	Occasionally braking load	General applications
Braking frequency(D)	20% ~30%	20 ~30%	50%~60%	5%	10%

The above Table 2-4 is a guide reference only, users can choose different braking resistance and power according to each application. However, please be remembered that the braking resistance shouldn't be less than the above recommended value, but the power is allowed to be exceed than the recommend numbers. Users need to select the right braking resistors according to each application case, there are quite a few aspects which will determine your choice of the resistors, such as the power of the motor, system inertia, deceleration time, the energy of the load etc. The greater the system inertia is, the shorter the required deceleration time is required, then the braking frequency will be increased, which means you need to choose a bigger power braking resistor with a lower braking resistance.

5 Installation and wiring

5.1 Installation

Please mount the inverter vertically indoors, with good ventilative conditions.

When selecting mounting environment, the followings should be taken into account:

Ambient temperature should be within the range of $-10\text{ }^{\circ}\text{C} \sim 40\text{ }^{\circ}\text{C}$. If the temperature is higher than $40\text{ }^{\circ}\text{C}$, the inverter should be derated and forced heat dissipation is required.

Humidity should be lower than 95%, non-condensing;

Mount in the location where vibration is less than 5.9m/s^2 (0.6g);

Mount in the location free of direct sunlight, dust, metal powder, corrosive gas or combustible gas;

If there are any special requirements for installation, please contact us for clarifications.

The requirements on mounting space and clearance are shown in figure 5-1 and 5-2;

When two inverters are mounted one on top the other, an air flow diverting plate should be fixed in between as shown in figure 5-3.

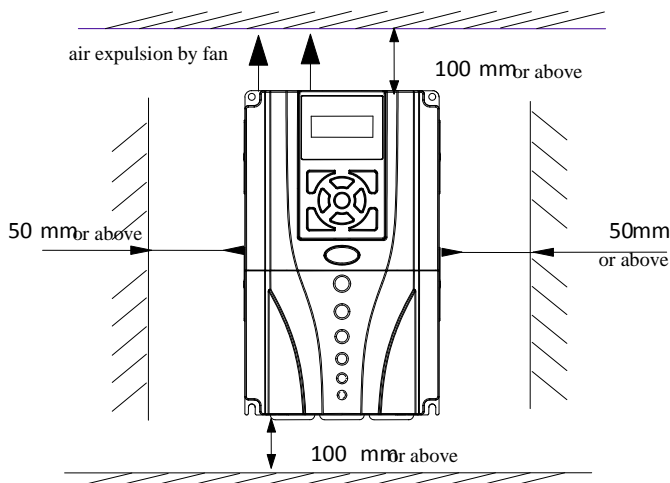

Figure 5-1 Installation clearance

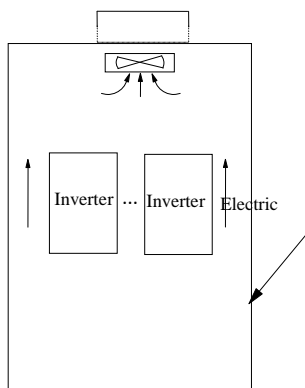

Figure5-2 Installation of several inverters

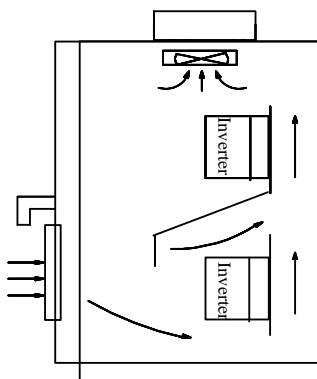

Figure5-3 Installation of one on top the other

5.1.1 EMC Compliance Installation

In a traction system composed of an inverter and a motor, if the inverter, controllers and transducer are installed in one cabinet, the disturbance they generate should be depressed at the connection points, therefore, a noise filter and inrush reactor should be installed in the cabinet, so that EMC requirement is met inside it.

The inverter is usually installed in a metal cabinet, the instruments outside the metal cabinet is shielded and may be disturbed lightly. The cables are the main EMI source, if you connect the cables in according to the manual, the EMI can be suppressed effectively.

In system design phase, to reduce EMI, insulating the noise source and use the noise subber are the best choice, but the choice is considerable. If there are a few sensitive devices on site, just install the power line filter beside them is enough note that the inverter and the contactor are noise source, and the automatic devices encoder and conductor are sensible to them. ◦

Divide the system into several EMC parts; refer to figure 5-4.

Note:

1. After installing EMI filter and AC reactor, the inverter can satisfy IEC 61800—3 standard.
 2. The input/output filter should be installed close to the inverter as possible.
-

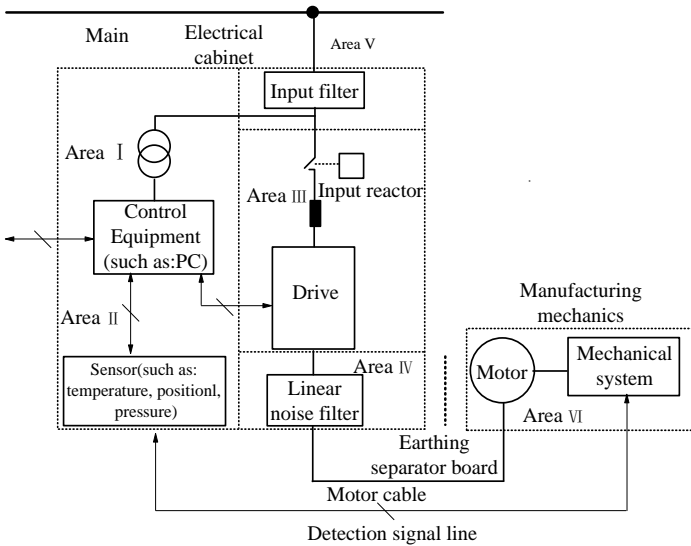

Figure 5-4 Recommended System Layout:

Area I : Should be used to install transformers for control power supply, control system and sensor.

Area II : should be used for interface of signal and control cables with good immunity level.

Area III: Should be used to install noise generating devices such as input reactor, inverter, brake unit and contactor.

Area IV : should be used to install output noise filter.

Area V : should be used to install power source and cables connecting the RFI filter.

Area VI: should be used to install the motor and motor cables.

Areas should be isolated in space, so that electro-magnetic decoupling effect can be achieved. The shortest distance between areas should be 20cm. Earthing bars should be used for decoupling among areas; the cables from different area should be placed in different tubes.

The filter should be installed at the interfaces between different areas if necessary. Bus cable (such as RS485) and signal cable must be shielded.

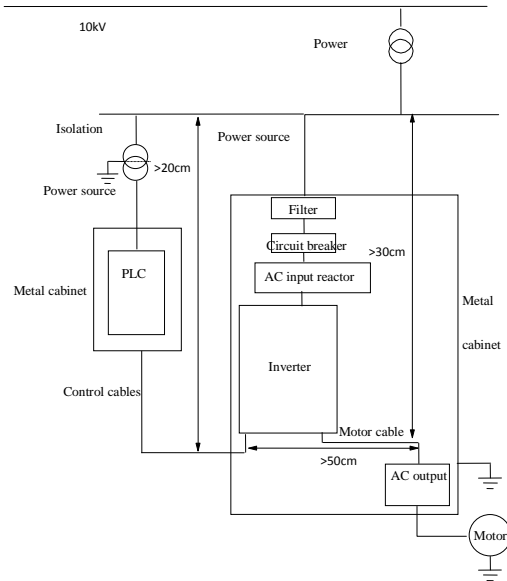

Figure 5-5 Installation of the inverter

5.1.2 Noise Suppression

The noise generated by the inverter may disturb the equipment nearby; the degree of disturbance is depend on the inverter system, immunity of the equipment, wire connections, installation clearance and earthing methods.

Noise emission paths	Actions to reduce the noise
<p>If the external equipment shares the same AC supply with the inverter, the inverter's noise may be transmitted along its input power supply cables, which may cause nuisance tripping to other external equipment. .</p>	<p>Install noise filter at the input side of the inverter, and use an isolation transformer or line filter to prevent the noise from disturbing the external equipment</p>

Noise emission paths	Actions to reduce the noise
<p>If the signal cables of measuring meters, radio equipment and sensors are installed in a cabinet together with the inverter, these equipment cables will be easily disturbed.</p>	<p>1) The equipment and the signal cables should be as far away as possible from the inverter.</p> <p>The signal cables should be shielded and the shielding layer should be grounded. The signal cables should be placed inside a metal tube and should be located as far away as possible from the input/output cables of the inverter. If the signal cables must cross over the power cables, they should be placed at right angle to one another.</p> <p>2) Install radio noise filter and linear noise filter (ferrite common-mode choke) at the input and output sides of the inverter to suppress the emission noise of power lines.</p> <p>3) Motor cables should be placed in a tube thicker than 2mm or buried in a cement conduit. Power cables should be placed inside a metal tube and be grounded by shielding layer (Motor cable should be a 4-core cable, where one core should be connected to the PE of the inverter and another should be connected to the motor's enclosure)</p>
<p>If the signal cables are routed in parallel with the power cables or bundle these cables together, the induced electro-magnetic noise and induced ESD noise may disturb the signal cables.</p>	<p>Avoid this kind of routing. Other equipment sensible to EMI should also be located as far away as possible from the inverter. The signal cables should be placed inside a metal tube and should be placed as far away as possible from the input/output cables of the inverter.</p> <p>The signal cables and power cables should be shielded cables. EMC interference will be further reduced if they could be placed inside metal tubes. The clearance between the metal tubes should be at least 20cm.</p>

Table5-1 Actions to reduce the noise

5.1.3 Using Surge Suppressor

The device such as relay, contactor and electro-magnetic braking kit, which may generate great noises, should be installed with surge suppressor even if installed outside of the device cabinet.

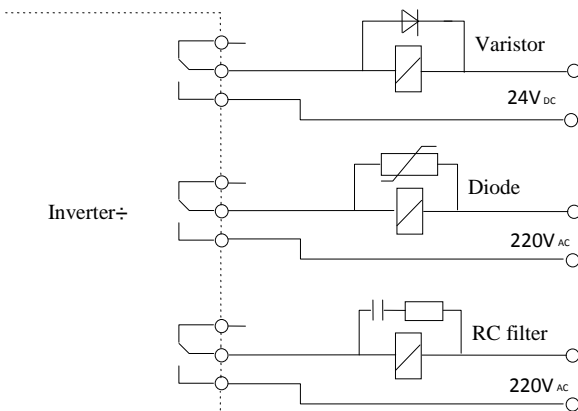

Figure5-6 Installation of Relay, contactor and electro-magnetic braking kit

5.1.4 Leakage Current

Leakage current may flow through the inverter's input and output capacitors and the motor's capacitor. The leakage current value is dependent on the distributed capacitance and carrier wave frequency. The leakage current includes ground leakage current and the leakage current between lines .

Ground leakage current

The ground leakage current not only flows into the inverter's system, but also into other equipment via earthing cables. It may cause leakage current circuit breaker and relays to be falsely activated. The higher the inverter's carrier wave frequency, the higher the leakage current, and also, the longer the motor's cable, the greater is the leakage current.

Suppressing methods:

Reduce the carrier wave frequency, but the motor noise may be higher;

Motor cables should be as short as possible;

The inverter and other equipment should use leakage current circuit breaker designed for protecting the products against high-order harmonic/surge leakage current .

Leakage current between lines

The line leakage current flowing outside though the distributed capacitor of the inverter may false trigger the thermal relay, especially for the inverter of which power rating is less than 7.5KW. If the cable is longer than 50m, the ratio of leakage current to motor rated current may increase to a level that can cause external thermal relay to trigger unexpectedly.

Suppression methods:

Reduce the carrier wave frequency, but the motor audible noise is higher;

Install reactor at the output side of the inverter.

In order to protect the motor reliably, it is recommended to use a temperature sensor to detect the motor's temperature, and use the inverter's over-load protection device (electronic thermal relay) instead of an external thermal relay.

5.1.5 Applications of Power Filter

Power source filter should be used in the equipment that may generate strong EMI or the equipment that is sensitive to EMI. The power source filter should be a low pass filter through which only 50Hz current can flow and high frequency current is rejected.

The power filter ensures the equipment can satisfy the conducting emission and conducting sensitivity in EMC standard. It can also suppress the radiated emission of the equipment

It can prevent the EMI generated by the equipment from entering power cable, and also prevent the EMI generated by the power cable from entering the equipment.

Common mistakes in using power line filter

Power cable is too long

The filter inside the cabinet should be located near to the input power source. The length of the cables should be as short as possible.

The input and output cables of the AC supply filter are too close

The distance between input and output cables of the filter should be as far apart as possible, otherwise the high frequency noise may be coupled between the cables and bypass the filter. Thus, the filtering effect becomes ineffective.

Bad earthing of filter.

The filter enclosure must be connected properly to the metal casing of the inverter. In order to be earthed well, a special earthing terminal on the filter's enclosure should be used. If you use one cable to connect the filter to the case, the earthing is useless due to high frequency interference. When the frequency is high, so too is the impedance of cable, hence there is little bypass effect.

The filter should be mounted in the enclosure of equipment. Ensure to clear away the insulation paint between the filter case and the enclosure for good earth contact.

5.1.6 AC Line Reactor Applications

Input AC Line Reactor:

A line reactor should be used if the distortion of power network is severe or the input current harmonic level is high even after a DC reactor has been connected to the inverter. It can also be used to improve the AC input power factor of the inverter.

Output AC Line Reactor:

When the cables from the inverter to motor are longer than 80m, multi-strand cables and an AC line reactor should be used to suppress the high frequency harmonics. Thus, the motor insulation is protected. At the same time, leakage current and unexpected trigger are reduced.

5.2 Wiring



- Wiring can only be done after the Variable Speed Inverter's AC power is disconnected; all the LEDs on the operation panel are off and after waiting for at least 10 minutes. Then, you can remove the panel.
- Wiring job can only be done after confirming the Charge indicator inside the inverter has extinguished and the voltage between main circuit power terminals + and - is below DC36V.
- Wire connections can only be done by trained and authorize personnel.
- For the sake of safety, the inverter and motor must be earthed because there is leakage current inside the inverter; Check the wiring carefully before connecting emergency stopping or safety circuits.
- Check the Variable Speed Inverter's voltage level before supplying power to it; otherwise human injuring or equipment damage may happen.



- Check whether the inverter's rated input voltage is in compliant with the AC supply voltage before using.
- Dielectric strength test of the inverter has been done in factory and the user needs not do it again
- Refer to chapter 2 on how to connect braking resistor or braking.
- It is prohibited to connect the AC supply cables to the inverter's terminals U, V and W.
- Grounding cables should be copper cables with cross-sectional area bigger than 2.5 mm^2 , and the grounding resistance should be less than 10Ω .
- For the sake of safety, the inverter and motor must be earthed because there is leakage current inside the inverter.



- The control circuits of SINUS VEGA are isolated from the power circuits in the inverter by basic insulation (single insulation) only. If the control cables are to connect to external control circuit exposing to human contact, an extra insulating layer, rated for use at the AC supply voltage of the load, must be applied.
- If the control circuits are to connect to other circuits classified as Safety Extra Low Voltage (SELV), e.g. connecting the RS485 port of the inverter to a personal computer through an adapter, an additional isolating barrier must be included in order to maintain the SELV classification.

⚠ CAUTION

The control terminals of the inverter are of ELV (Extra Low Voltage) circuit. Do not touch them once energized;

If the external device has touchable terminals of SELV (Safety Extra Low Voltage) circuit. Remember to connect isolating protections in between. Otherwise, the SELV circuit will be degraded to ELV circuit;;

When connecting the inverter with PC, do choose RS485/232 adapters with isolating protections that measure up to safety

requirements. .

5.2.1 Overview

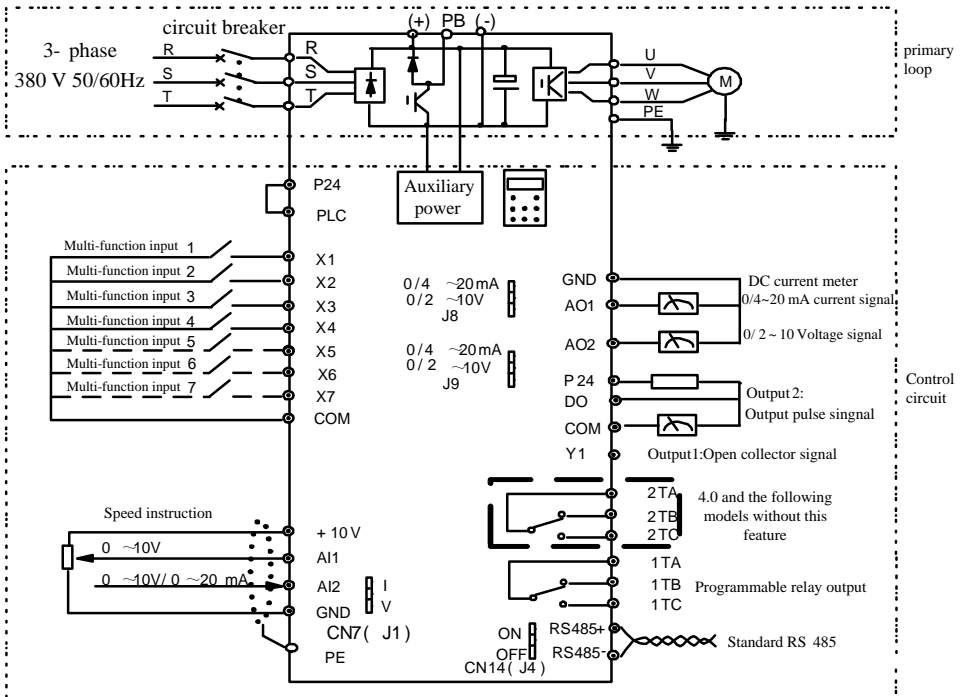

Figure 5-7 Systematic Wiring Diagram

Table 5-2 Recommended MCCB Capacity and Copper Cable Section Area

Size	Model	MCCB Circuit breaker (A)	Power circuit (mm ²)				Control cable (mm ²)
			Input cable	Braki ng line	Outpu t cable	Earth cable	
K05	SINUS VEGA 0005 4T	25	2.5	1.5	2.5	2.5	1.0
K10	SINUS VEGA 0007 4T	32	4.0	2.5	4.0	4.0	1.0
K10	SINUS VEGA 0011 4T	32	4.0	2.5	4.0	4.0	1.0
K15	SINUS VEGA 0015 4T	40	6.0	4.0	6.0	6.0	1.0
K15	SINUS VEGA 0018 4T	63	6.0	4.0	6.0	6.0	1.0
K40	SINUS VEGA 0022 4T	63	10	10	10	10	1.0
K40	SINUS VEGA 0030 4T	80	16	16	16	16	1.0
K45	SINUS VEGA 0037 4T	100	25	25	25	16	1.0
K45	SINUS VEGA 0045 4T	160	25	10	25	16	1.0
K50	SINUS VEGA 0055 4T	200	35	16	35	16	1.0
K50	SINUS VEGA 0075 4T	200	35	25	35	25	1.0
K50	SINUS VEGA 0090 4T	250	70	Pls refer to brake resisto r manua l	70	35	1.0
K55	SINUS VEGA 0110 4T	310	70		70	35	1.0
K55	SINUS VEGA 0132 4T	400	95		95	50	1.0
K55	SINUS VEGA 0160 4T	400	150		150	75	1.0

Note:

If the control circuit uses multi-strand cable, the single-core cable section area can be 0.5mm².

5.2.2 Power Terminals

1. SINUS VEGA 0005 4T





	R	S	T	(+)	(-)	PB	U	V	W
---	---	---	---	-----	-----	----	---	---	---

Table 3-4 Definitions of power terminals

Mark	Definition
R、S、T	3-phase AC input
+、PB	External braking resistor
+、—	DC positive, negative bus input
U、V、W	3-phase AC outputs
	Protective earth

2. SINUS VEGA 0007 4T~ 0018 4T

R	S	T	P1	(+)	PB	(-)	U	V	W
---	---	---	----	-----	----	-----	---	---	---

	
---	---

3. SINUS VEGA 0022 4T ~ 0030 4T

PE	R	S	T	PB	(+)	(-)	U	V	W	PE
----	---	---	---	----	-----	-----	---	---	---	----

P1

4. SINUS VEGA 0037 4T ~ 0075 4T

R	S	T	P1	(+)	PB	(-)	U	V	W	PE
---	---	---	----	-----	----	-----	---	---	---	----

5. SINUS VEGA 0090 4T and above:

Into the terminal
(at the top of the machine)

PE	R	S	T
----	---	---	---

At the bottom of the
outlet terminals
(machine)

PE	U	V	W	P1	(+)	(-)
----	---	---	---	----	-----	-----

Table 5-3Definitions of power terminals

Mark	Definition
R、S、T	3-phase AC input
P1、 (+)	External DC reactor reserved terminals (connect with steel before use)

Mark	Definition
(+) 、 PB	External braking resistor
(-)	DC negative bus input
U、 V、 W	3-phase AC outputs
PE	Protective earth

5.2.3 Control Circuit Wiring

Control Terminals and Jumpers

Refer the layout to Figure 5-8. Jumper’s functions in 5-7. Be sure to set the jumper and wire the terminals properly. It is recommended to use cable of section area bigger than 1mm².

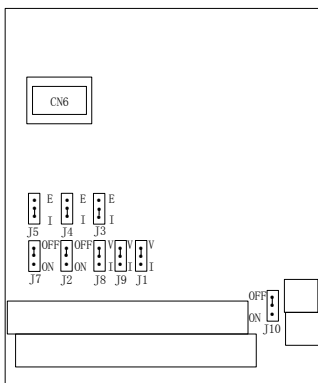

Figure 5-8 Layouts of control terminals and jumpers

See below configuration of jumpers

Table 5-4 Jumpers’ function

Mark	Function&Setting	Default
J1	AI2current/voltage input selection I: 0~20mA current signal V: 0~+10V voltage signal	0~+10V
J2	485 terminal resistor selection: ON: 120Ω terminal resistor, OFF: No terminal resistor.	No resistor
J3、 J4 and J5	Communication selection	
J7 and J10	Reserved	

Mark	Function&Setting	Default
J8	AO1 current/voltage input selection 0/4~20mA: AO1 current signal 0/2~+10V: AO1 voltage signal	0~+10V
J9	AO2 current/voltage input selection 0/4~20mA: AO2 current signal 0/2~+10V: AO2 voltage signal	0~+10V

Jumper usage

J1 jumper usage:

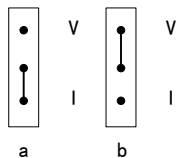

Figure a means that 0~+10V analog voltage input is selected;

Figure b means that 0/4~20mA analog current input is selected.

J2 jumper usage:

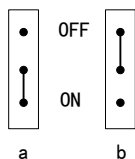

Figure a means that there is no resistor (ON);

Figure b means that there is a resistor (OFF) .

J8 and J9 jumper usage:

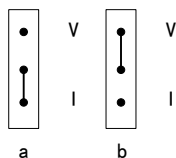
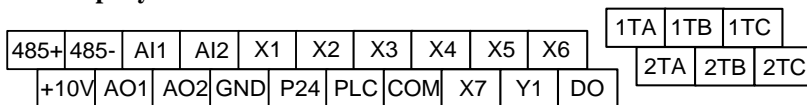

Figure a means that 0~+10V analog voltage output is selected;

Figure b means that 0/4~20mA analog current output is selected.

Terminal strip layout



TA-TB: Normally closed; TA-TC: Normally open

Contact capacity: 250Vac/2A (COSφ=1), 250Vac/1A (COSφ=0.4), 30Vdc /1A

TA, TB and TC can be defined as multi-functional digital output signals. Please refer to Section 5.7

Relay output TA、TB、TC Wiring:

If there are inductive loads, such as: electro-magnetic relay and contactor, surge snubber circuit, e.g. RC circuit, varistor, fly-wheel diode (pay attention to the polarity when used in a DC circuit), should be installed. Note that the leakage current should be less than the current in the contactor or relay. The components in the snubber circuit should be installed near to the relay or contactor coil.

Note:

The “+RS485-” in the above figure means RS485+ and RS485-.

Terminals of main control board

Table 5-5 Terminal function table

Category	Terminals	Name	Function	Specification
Communication	485+	RS485 communication port	RS485+	Standard RS-485 communication port, please use twisted-pair cable or shielded cable
	485-		RS485-	
Analog input	AI1	Analog input AI1	Analog voltage input (reference ground: GND)	Input voltage range:0~+10V (input resistance:100kΩ) resolution:1/2000
	AI2	Analog input AI2	Accepting analog voltage/current input. Jumper can select voltage or current input mode, Voltage input mode is the default (Reference ground: GND)	Input voltage range:0~+10V (input resistance:100kΩ) Input current range:0~20mA (input resistance:500Ω) resolution:1/2000

Category	Terminals	Name	Function	Specification
Analog output	AO1	Analog output 1	Be able to output analog voltage/current. Jumper can select voltage or current input mode. Voltage input mode is the default mode.	Output current range: 0/4~20mA
	AO2	Analog output 2	Be able to output analog voltage/current. Jumper can select voltage or current input mode, Voltage input mode is the default mode.	Output voltage range: 0/2~+10V
Digital input	X1~ X4,X6,X7	Multi-functional digital inputs 1~3	Can be defined as multi-functional digital inputs,Reference ground: COM	Optical-isolator 2-way input input resistance: 2kΩ maximum input frequency: 200Hz Input voltage range: 9~30V
	X5	Multi-functional digital inputs 5	It can be defined as high-speed pulse inputs. Reference ground: COM	Optical-isolator 2-way input Single way max. input frequency: 100kHz, 2-way max. input frequency: 50kHz Max. reference pulse frequency: 50Hz Input voltage range: 9~30V Input impedance: 2Ω
	PLC	Common terminal	Common terminal for multi-functional inputs	
	F24	+24V supply	Providing +24V power supply	Output: +24V, set point accuracy: ±10% Max output current: 200mA (150mA for 2S0007G and 2S0004G)
	COM	+24V common terminal	Isolated internally with GND	Isolated internally with GND
Digital output	Y1	Open collector output 1	Programmable terminals, defined as multi-function digital outputs.	Optical-isolator output: 24VDC/50mA

Category	Terminals	Name	Function	Specification
	DO	Open collector output 2	Programmable terminals, defined as multi-function digital outputs.	Optical-isolator output: 24VDC/50mA, DO can be used as digital output, Max output frequency :50kHz
Power supply	+10V	+10V power supply	Provide +10V power supply	Output: +10V, Setpoint accuracy: $\pm 10\%$ Max. output current: 100mA
	GND	GND of +10V power supply	reference ground of analog signal and +10V power supply	Isolated internally with COM
Others	1TA/1TB/ 1TC/2TA/ 2TB/2TC	Relay output	TA, TB and TC can be defined as multi-functional digital output signals.	TA-TB: normally closed; TA-TC: normally open Contact capacity: 250Vac/2A (COS ϕ =1) , 250Vac/1A (COS ϕ =0.4) , 30 Vdc /1A

1) Analog Input Terminal Wiring

①Terminal AI1 receives analog voltage input, the wiring is as follows:

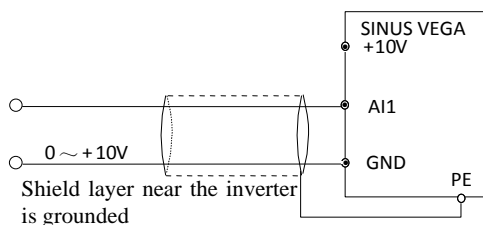

Figure 5-9 AI1 Wiring Diagram

②Terminal AI2 receives analog signal. Select current or voltage signal by setting jumper. Refer to the figure below:

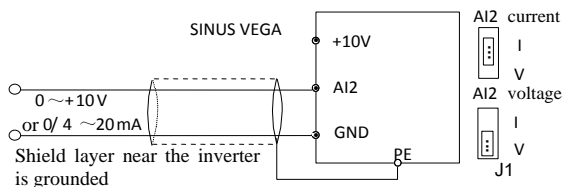

Figure 5-10 AI2 Wiring Diagram

2) Analog Output Terminal Wiring

If the analog output terminal AO1 and AO2 are connected with analog meter, it can measure many parameters. The jumpers for AO1 and AO2 are J8 and J9.

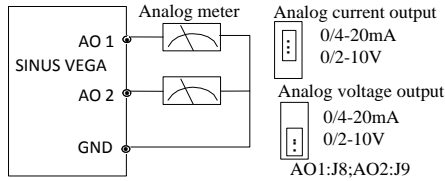

Figure 5-11 Analog Output Terminal Wiring

Note:

1. When using analog input, you should install capacitor-filter or common-mode inductor between AI1 and GND, or between AI2 and GND.
2. Analog I/O signals are sensible to interference, ensure to use shielded cable and ground it properly. The cable length should be as short as possible.

3) Serial Communication Port Connection

The inverter can be connected to the host with RS485 port directly.

Figure 5-12 shows the connection of the inverter with the host with RS232 port.

Using above wiring method, you can built a “single-master single-slave” system or a “single-master multi-slaves” system. The inverter in the network can be monitored, can be controlled remotely automatically in real time by using a PC or PLC controller. Thus more complicated operation control can be realized.

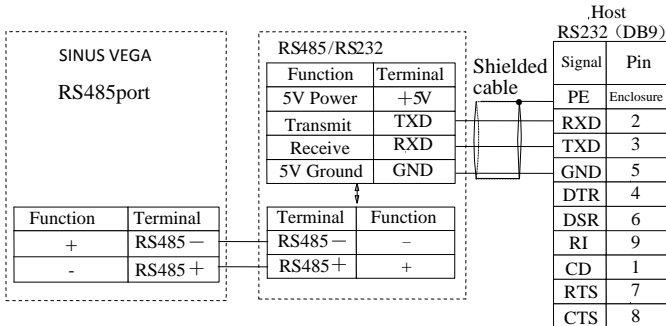

Figure 5-12 RS485- (RS485/RS232) -RS232 communication cable

Precautions for communication port connection:

The PE terminal of each inverter should be earthed at a nearby grounding point;

The GND terminal of each inverter should be connected together;

RS485 communication uses shielded cables, which is earthed at one side. The earth wire of the shielded cable is connected to RS485 communication module (PE).

If the above standard wiring methods cannot meet the requirements, you can take the actions below:

Use isolated RS485 communication module;

If the noise is transmitted through the GND line to the inverter or other devices, which results in malfunction of them, you may disconnect the GND lines.

4) Multi-function Input Terminal and Wiring

The multi-function input terminals use full-bridge rectifying circuit, as the below figure shows. PLC is the common terminal for X1~X7. The PLC terminal can sink or source current. Wire connections X1~X7 is flexible and the typical wiring is shown below:

□ Connection method 1

It is default to use the inverter's internal power source 24V, i.e. PLC connected with P24.

If you want to use external power supply, make sure to remove the wire between PLC and P24.

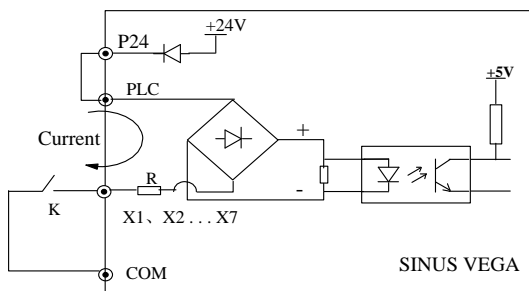

Figure 5-13 External power supply wiring diagram

□ Connection Method 2

Inverter's internal +24V power supply is used and the external controller uses PNP transistors whose common emitters are connected, as shown in Figure 5-14.

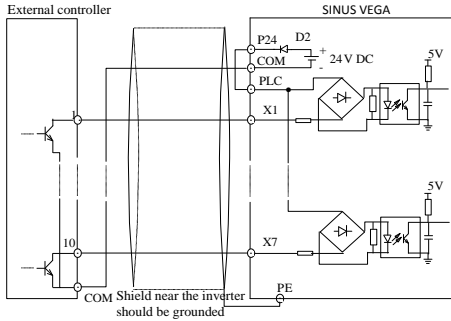

Figure 5-14 Internal +24V wiring diagram (source)

Inverter's internal +24V power supply is used and the external controller uses PNP transistors whose common emitters are connected. (Remove the wire between PLC and P24) .

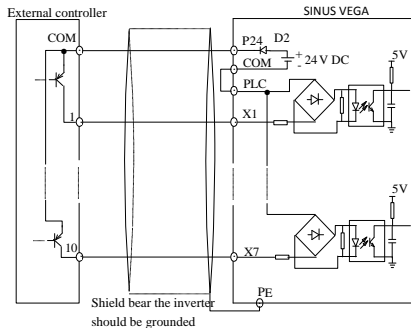

Figure 5-15 Internal +24V wiring diagram (drain)

When using External power supply, remember to disconnect PLC and P24

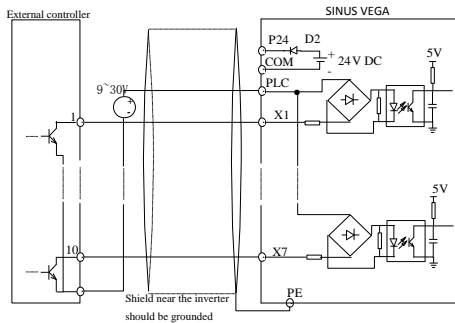

Figure 5-16 External power supply wiring (source)

External power supply wiring (drain) (Remember to disconnect PLC and P24)

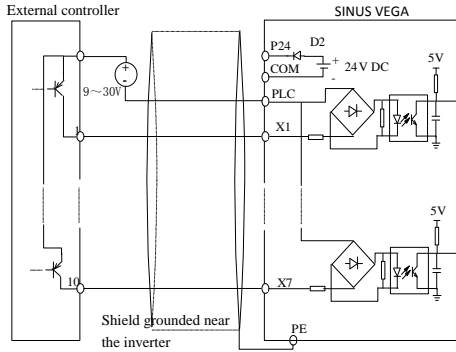

Figure 5-17 External power supply wiring (drain)

5) Multi-function Output Terminal Wiring

- Terminal Y1 can use the internal 24V power supply, see the figure below:

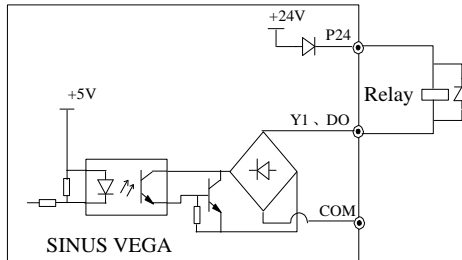

Figure 5-18 Multi-function output terminal wiring1

- Terminal Y1 can also use external power (9~30V) supply:

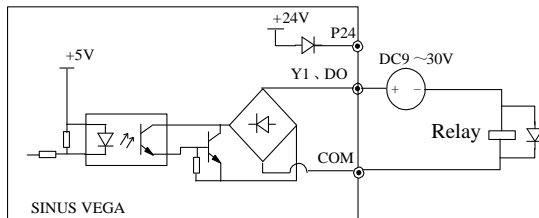

Figure 5-19 Multi-function output terminal wiring2

- ③ When Terminal DO is used as digital pulse frequency output, it can also use the internal 24V power supply:

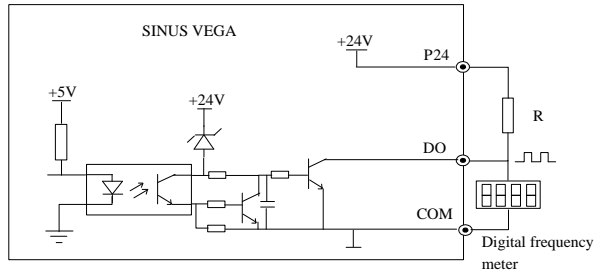

Figure 5-20 Terminal DO wiring 1

④ When Terminal DO is used as digital pulse frequency output, it can also use the external power supply (9~30V):

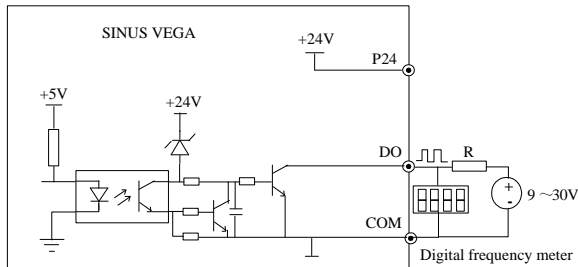

Figure 5-21 Terminal DO wiring 2

Note:

1. Don't short terminals P24 and COM, otherwise the control board may be damaged.
2. Use multi-core shielded cable or multi-strand cable (above 1mm) to connect the control terminals.
3. When using a shielded cable, the shielded layer's end that is nearer to the inverter should be connected to PE.
4. The control cables should be as far away (at least 20cm) as possible from the main circuits and high voltage cables (including power supply cables, motor cables, relay cables and cables of contactor). The cables should be vertical to each other to reduce the disturbance to minimum.

5.2.4 Onsite Wiring Requirements

To avoid mutual EMI disturbance, the control cables, power cable and motor cable should be installed as apart as possible, especially when they are routed in parallel for rather long distance. If the signal cable must cross the power cable or motor cable, keep them at right angle to each other.

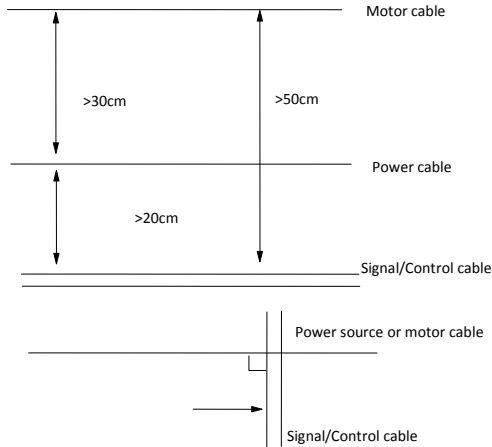

Figure 5-22 Cable routing schematic diagram

If the section area of the motor cable is too big, the motor should derate. Refer the inverter’s cable specs in Table 5-2. Since the larger the section area of cables, the greater their capacitance to the ground, therefore, the output current should derate 5% with increasing every category of cable section area

Shielded/armored cable: high-frequency low-impedance shielded cable should be used, such as woven copper mesh, aluminum mesh or metal mesh.

The control cable should be shielded, and the clamps at both ends of the metal mesh should be connected to the earth terminal of the inverter enclosure.

Use conductive plate and dentate pad to clear away the paint between the screws and metal casing, to ensure good conductivity.

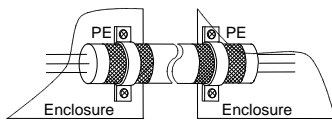

Figure 5-23 Correct shield layer earthing

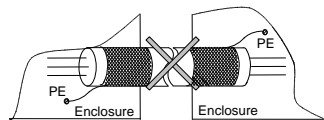

Figure 5-24 Incorrect shield layer earthing

5.2.5 Earthing

Independent earthing pole(recommended)

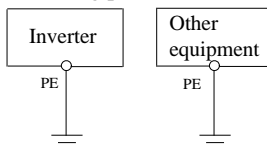

Figure 5-25 Earthing Diagram 1

Shared earthing pole(acceptable)

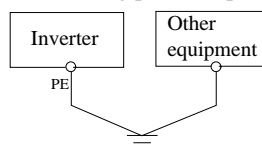

Figure 5-26 Earthing Diagram 2

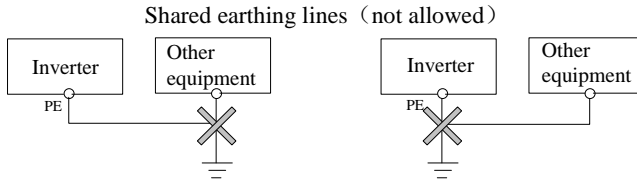

Figure 5-27 Earthing Diagram 3

Besides, pay attention to the following points:

In order to reduce the earthing resistance, flat cable should be used because the high frequency impedance of flat cable is smaller than that of round cable with the same CSA.

For 4-core motor cable, the end of one cable should be connected to the PE of the inverter, and the other end should be connected to the motor's enclosure. If the motor and the inverter each have its own earthing pole, then the earthing effect is better.

If the earthing poles of different equipment in one system are connected together, then the leakage current will be a noise source that may disturb the whole system. Therefore, the inverter's earthing pole should be separated with the earthing pole of other equipment such as audio equipment, sensors and PC, etc.

In order to reduce the high frequency impedance, the bolts used for fixing the equipment can be used as the high frequency terminal. The paints on the bolt should be cleaned.

The earthing cable should be as short as possible, that is, the earthing point should be as close as possible to the inverter.

Earthing cables should be located as far away as possible from the I/O cables of the equipment that is sensitive to noise, and lead should also be as short as possible.

6. Operation Procedures

6.1 AC Drive Operation Panel

◆ Operation Panel Appearance and Key Function Description

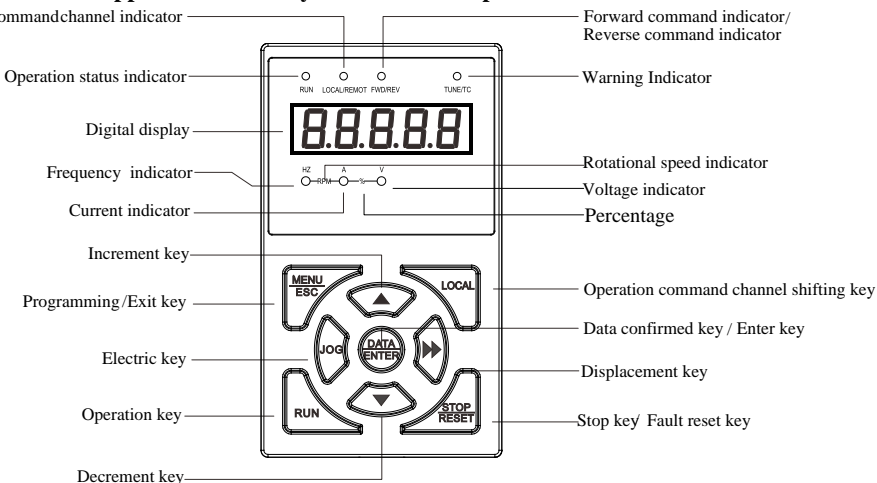

Parameter unit indicator

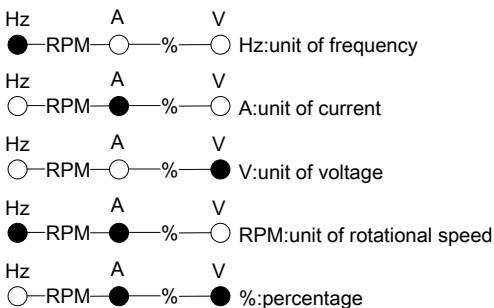

There are 9 keys on AC drive operation panel. Function of each key is defined as the table 6-1:

Table 6-1: Operation Panel Menu

Key	Name	Function
MENU/ESC	Programming / Exit key	Enter or exit programming status
DATA/ENTER	Function/Data key	Enter next menu or data identification
▲	Increment key	Increment of data or function code

Key	Name	Function
▼	Decrement key	Decrement of data or function code
▶▶	Displacement key	Under editing, the modified position of setting data may be selected. Under other status, the status Parameter may be displayed shifted.
LOCAL	Operation command channel shifting key	Select operation command channel in order, press the DATA/ENTER key to ensure
JOG	Inching key	Under operation panel, press the key for inching operation
RUN	Operation key	Under operation panel, press the key for operation
STOP/RESET	Stop/Reset key	Halt or failure reset

◆ Operations of Parameters

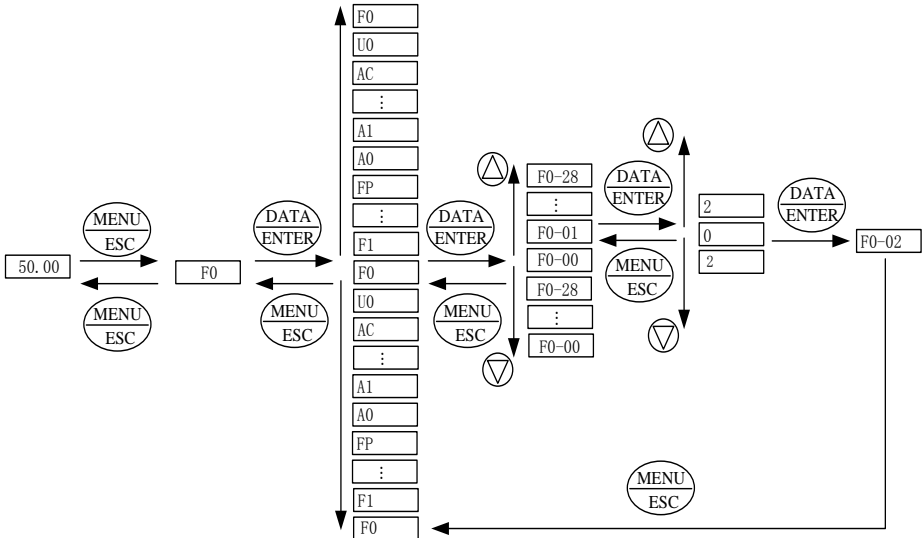

7 Description of Function Codes

7.1 Group F0: Basic Parameters

F0-00	Type display		Default	Model dependent
	Setting Range	1	HEAVY DUTY	
		2	NORMAL DUTY	

This Parameter is used to display the delivered model and cannot be modified

1: HEAVY DUTY

2: NORMAL DUTY

F0-01	Motor 1 control mode		Default	0
	Setting Range	0	Sensor less flux vector control (SVC)	
		1	Closed-loop vector control (FVC)	
		2	Voltage/Frequency (V/F) control	

0: Sensor less flux vector control (SVC)

It indicates open-loop vector control, and is applicable to high-performance control applications such as machine tool, centrifuge, wire drawing machine and injection moulding machine. One AC drive can operate only one motor. Torque control can be implemented in the SVC mode.

1: Closed-loop vector control (FVC)

It is applicable to high-accuracy speed control or torque control applications such as high-speed Paper making machine, crane and elevator. One AC drive can operate only one motor. An encoder must be installed at the motor side, and a encoder card matching the encoder must be installed at the AC drive side. Torque control can be implemented in the FVC mode.

2: Voltage/Frequency (V/F) control

It is applicable to applications with low load requirements or applications where one AC drive operates multiple motors, such as fan and pump.

Note: If vector control is used, motor auto-tuning must be performed because the advantages of vector control can only be utilized after correct motor Parameters are obtained. Better performance can be achieved by adjusting speed regulator Parameters in group F2 (or groups A2, A3, and A4 respectively for motor 2, 3, and 4).

For the permanent magnetic synchronous motor (PMSM), the SINUS VEGA does not support SVC. FVC is used generally. In some low-power motor applications, you can also use V/F.

F0-02	Command source selection		Default	0
	Setting Range	0	Operation Panel control (LED off)	
		1	Terminal control (LED on)	
		2	Communication control (LED blinking)	

It is used to determine the input channel of the AC drive control commands, such as run, stop, forward rotation, reverse rotation and jog operation.

0: Operation Panel control channel (“LOCAL/REMOT” indicator off)

Commands are given by pressing keys “RUN” and “STOP/RES” on the operation Panel

1: Terminal control (“LOCAL /REMOT” indicator on)

Commands are given by means of multifunctional input terminals with functions such as FWD, REV, JOGF, and JOGR.

2: Communication control channel (“LOCAL/REMOT” indicator blinking)

Commands are given from host computer. If this Parameter is set to 2, a communication card (Modbus RTU) must be installed

Related to the communication function Parameters, please see the "FD group communication Parameters" instructions, and reference the corresponding communication card, the appendix of this manual contains brief explanation of communication card.

F0-03	Main frequency source X selection		Default	0
	Setting Range	0	Digital setting (Preset frequency F0-08, UP/DOWN revisable, non-retentive at power failure)	
		1	Digital setting (Preset frequency F0-08, UP/DOWN revisable, retentive at power failure)	
		2	AI1	
		3	AI2	
		4	AI3	
		5	Pulse setting (X5)	
		6	Multi-reference	
		7	PLC	
		8	PID	
		9	Communication setting	

It is used to select the setting channel of the main frequency. You can set the main frequency in the following 10 channels:

0: Digital setting (non-retentive at power failure)

The initial value of the set frequency is the value of F0-08 (Preset frequency). You can change the set frequency by pressing ▲ and ▼ on the operation Panel (or using the UP/DOWN functions of input terminals).

When the AC drive is powered on again after power failure, the set frequency reverts to the value of F0-08.

1: Digital setting (retentive at power failure)

The initial value of the set frequency is the value of F0-08 (Preset frequency). You can change the set frequency by pressing keys ▲ and ▼ on the operation Panel (or using the UP/DOWN functions of input terminals).

When the AC drive is powered on again after power failure, the set frequency is the value memorized at the moment of the last power failure.

Note that F0-23 (Retentive of digital setting frequency upon power failure) determines whether the set frequency is memorized or cleared when the AC drive stops. It is related to stop rather than power failure.

2: AI1

3: AI2

4: AI3

The frequency is set by analog input. The SINUS VEGA control board provides two analog input terminals (AI1, AI2). Another AI terminal (AI3) is provided by the I/O extension card.

AI1 is 0V~+10V voltage input, AI2 can be 0V~+10V voltage input, or 4mA ~ 20mA current input, it is determined by jumper J8, AI3 is -10V~+10V voltage input.

The SINUS VEGA provides five curves indicating the mapping relationship between the input voltages of AI1, AI2 and AI3 and the target frequency, three of which are linear (point - point) correspondence and two of which are four-point correspondence curves. You can set the curves by using function codes F4-13 to F4-27 and function codes in group A6, and select curves for AI1~AI3 in F4-33. For the five curves specific corresponding relations, please refer to the F4, A6 group function code.

5: Pulse setting (X5)

The frequency is set by X5 (high-speed pulse). The signal specification of pulse setting is 9–30 V (voltage range) and 0–100 kHz (frequency range). Input pulse can only be given from multifunctional input terminals X5. The relation between X5 terminal input pulse frequency and the corresponding set, is designed through the F4-28, the corresponding relation of two points is straight line corresponding relation. The corresponding value 100% of pulse setting corresponds to the value of F0-10 (Maximum frequency).

6: Multi-reference

In multi-reference mode, combinations of different X terminal states correspond to different set frequencies. The SINUS VEGA supports a maximum of 16 speeds implemented by 16 state combinations of four X terminals (allocated with functions 12 to 15) in Group FC. The multiple references indicate percentages of the value of F0-10 (Maximum frequency).

If a X terminal is used for the multi-reference function, you need to perform related setting in group F4.

The SINUS VEGA supports Modbus computer communication protocols.

If the communication mode is used, a communication card must be installed. The SINUS VEGA provides four optional communication cards and you can select one based on actual requirements. If the communication protocol is Modbus, the corresponding serial communication protocol needs to be selected based on the setting of F0-28.

7: Simple PLC

When the simple programmable logic controller (PLC) mode is used as the frequency source, the running frequency of the AC drive can be switched over among the 16 frequency references. You can set the holding time and acceleration/deceleration time of the 16 frequency references. For details, refer to the descriptions of Group FC.

8: PID

The output of PID control is used as the running frequency. PID control is generally used in on-site closed-loop control, such as constant pressure closed-loop control and constant tension closed-loop control.

When applying PID as the frequency source, you need to set parameters of PID function in group FA.

9: Communication setting

The frequency is set by means of communication.

If the AC drive is a slave in point-point communication and receives data as the frequency source, data transmitted by the master is used as the set frequency. For details, see the description of group A8.

F0-04	Auxiliary frequency source Y selection	Default	0
	Setting Range	0	Digital setting (preset frequency F0-08, UP/DOWN revisable, non-retentive power failure)
		1	Digital setting (preset frequency F0-08, UP/DOWN revisable, retentive at power failure)
		2	AI1
		3	AI2
		4	AI3
		5	Pulse setting (X5)
		6	Multi-reference
		7	PLC
		8	PID
9	Communication setting		

When used as an independent frequency input channel (frequency source switched over from X to Y), the auxiliary frequency source Y is used in the same way as the main frequency source X (refer to F0-03).

When the auxiliary frequency source is used for operation (frequency source is "X and Y operation"), Pay attention to the following aspects:

1. If the auxiliary frequency source Y is digital setting, the preset frequency (F0-08) does not take effect. You can directly adjust the set main frequency by pressing keys ▲ and ▼ on the operation Panel (or using the UP/DOWN function of input terminals).
2. If the auxiliary frequency source is analog input (AI1, AI2 and AI3) or pulse setting, 100% of the input corresponds to the range of the auxiliary frequency Y (set in F0-05 and F0-06).
3. If the auxiliary frequency source is pulse setting, it is similar to analog input.

Note: The main frequency source X and auxiliary frequency source Y must not use the same channel. That is, F0-03 and F0-04 cannot be set to the same value.

F0-05	Range of auxiliary frequency Y for X and Y operation	Default	0
	Setting Range	0	Relative to maximum frequency
1		Relative to main frequency X	
F0-06	Range of auxiliary frequency Y for X and Y operation	Default	0
	Setting Range	0% ~ 150%	

If X and Y operation is used, F0-05 and F0-06 are used to set the adjustment range of the auxiliary frequency source.

You can set the auxiliary frequency to be relative to either maximum frequency or main frequency X. If relative to main frequency X, the setting range of the auxiliary frequency Y varies according to the main frequency X.

F0-07	Frequency source selection		Default	0
	Setting Range	Unit's digit	Frequency source selection	
		0	Main frequency source X	
		1	X and Y operation (operation relationship determined by ten's digit)	
		2	Switchover between X and Y	
		3	Switchover between X and "X and Y operation"	
		4	Switchover between Y and "X and Y operation"	
		Ten's digit	X and Y operation relationship	
		0	X + Y	
		1	X - Y	
		2	Maximum	
		3	Minimum	

It is used to select the frequency setting channel. If the frequency source involves X and Y operation, you can set the frequency offset in F0-21 for superposition to the X and Y operation result, flexibly satisfying various requirements.

Unit's digit: Frequency source selection

0: Main frequency source X

Main frequency source X as target frequency

1: X and Y operation

Main and auxiliary operation result as the target frequency, main and auxiliary operation relationship see the description of ten digits.

2: Main frequency source X and auxiliary frequency Y switchover

When the multi-function input terminals function 18 (frequency switch) is invalid, the main frequency X as the target frequency.

When the multi-function input terminals function 18 (frequency switch) is valid, the auxiliary frequency Y as the target frequency.

3: The main frequency source X switchover with the main and auxiliary operation result.

When the multi-function input terminals function 18 (frequency switch) is invalid, the main frequency X as the target frequency.

When the multi-function input terminals function 18 (frequency switch) is valid, the main and auxiliary operation result as the target frequency.

4: The auxiliary frequency source Y switchover with the main and auxiliary operation result.

When the multi-function input terminals function 18 (frequency switch) is invalid, the auxiliary frequency Y as the target frequency.

When the multi-function input terminals function 18 (frequency switch) is valid, the main and auxiliary operation result as the target frequency.

Ten digits: Frequency source main and auxiliary operation relations.

0: X+Y

The target frequency is the sum of main frequency X and auxiliary frequency Y.

1: X-Y

The target frequency is the difference between main frequency X and auxiliary frequency Y.

2: MAX

The target frequency is the largest absolute value of main frequency X and auxiliary frequency Y.

3: MIN

The target frequency is the least absolute value of main frequency X and auxiliary frequency Y.

In addition, when the frequency source selection is X and Y, offset frequency can be set by F0-21, offset frequency, superimposed on the advocate complementary operation results in a flexible response to various needs.

F0-08	Preset frequency	Default	50.00Hz
	Setting Range	0.00~maximum frequency (valid when frequency source is digital setting)	

If the frequency source is digital setting or terminal UP/DOWN, the value of this Parameter is the initial frequency of the AC drive (digital setting)

F0-09	Rotation direction		Default	0
	Setting Range	0	Same direction	
		1	Reverse direction	

You can change the rotation direction of the motor just by modifying this Parameter without changing the motor wiring. Modifying this Parameter is equivalent to exchanging any two of the motor's U, V, W wires.

Note: The motor will resume running in the original direction after Parameter initialization. Do not use this function in applications where changing the rotating direction of the motor is

prohibited after system commissioning is complete.

F0-10	Maximum frequency	Default	50.00 Hz
	Setting Range	50.00Hz ~ 320.00Hz	

When the frequency source is AI, pulse setting (X5), or multi-reference, 100% of the input corresponds to the value of this Parameter.

The output frequency of the SINUS VEGA can reach up to 3200 Hz. To take both frequency reference resolution and frequency input range into consideration, you can set the number of decimal places for frequency reference in F0-22.

If F0-22 is set to 1, the frequency reference resolution is 0.1 Hz. In this case, the setting range of F0-10 is 50.0 to 3200.0 Hz.

If F0-22 is set to 2, the frequency reference resolution is 0.01 Hz. In this case, the setting range of F0-10 is 50.00 to 320.00 Hz.

F0-11	Source of frequency upper limit	Default	0
	Setting Range	0	Set by F0-12
		1	AI1
		2	AI2
		3	AI3
		4	PULSE setting (X5)
		5	Communication setting

It is used to set the source of the frequency upper limit, including digital setting (F0-12), AI, pulse setting or communication setting. If the frequency upper limit is set by means of analog input, the analog input setting is 100% corresponding to F0-12.

For example, to avoid runaway in torque control mode in winding application, you can set the frequency upper limit by means of analog input. When the AC drive reaches the upper limit, it will continue to run at this speed.

F0-12	Frequency upper limit	Default	50.00Hz
	Setting Range	Frequency lower limit F0-14 ~ maximum frequency F0-10	
F0-13	Frequency upper limit offset	Default	0.00Hz
	Setting Range	0.00Hz ~ maximum frequency F0-10	

If the source of the frequency upper limit is analog input or pulse setting, the final frequency upper limit is obtained by adding the offset in this Parameter to the frequency upper limit set in F0-11

F0-14	Frequency lower limit	Default	0.00Hz
	Setting Range	0.00Hz ~ frequency upper limit F0-12	

If the frequency reference is lower than the value of this Parameter, the AC drive can stop, run at the frequency lower limit, or run at zero speed, determined by F8-14.

F0-15	Carrier frequency	Default	Model dependent
	Setting Range	0.5kHz ~ 16.0kHz	

It is used to adjust the carrier frequency of the AC drive, helping to reduce the motor noise, avoiding the resonance of the mechanical system, and reducing the leakage current to the earth and interference generated by the AC drive.

If the carrier frequency is low, output current has high harmonics, and the power loss and temperature rise of the motor increase.

If the carrier frequency is high, power loss and temperature rise of the motor declines.

However, the AC drive has an increase in power loss, temperature rise and interference.

Adjusting the carrier frequency will exert influences on the aspects listed in the following table:

Carrier frequency	Low	→	High
Motor noise	Large	→	Small
Output current waveform	Bad	→	Good
Motor temperature rise	High	→	Low
AC drive temperature rise	Low	→	High
Leakage current	Small	→	Large
External radiation interference	Small	→	Large

The factory setting of carrier frequency varies with the AC drive power. If you need to modify the carrier frequency, note that if the set carrier frequency is higher than factory setting, it will lead to an increase in temperature rise of the AC drive's heatsink. In this case, you need to de-rate the AC drive. Otherwise, the AC drive may overheat and alarm.

F0-16	Carrier frequency adjustment with temperature	Default	1
	Setting Range	0: No 1: Yes	

It is used to set whether the carrier frequency is adjusted based on the temperature. The AC drive automatically reduces the carrier frequency when detecting that the heatsink temperature is high. The AC drive resumes the carrier frequency to the set value when the heatsink temperature becomes normal. This function reduces the overheat alarms.

F0-17	Acceleration time 1	Default	Model dependent
	Setting Range	0.00s ~ 650.00s (F0-19=2) 0.0s ~ 6500.0s (F0-19=1) 0s ~ 65000s(F0-19=0)	
F0-18	Deceleration time 1	Default	Model dependent
	Setting Range	0.00s ~ 650.00s (F0-19=2) 0.0s ~ 6500.0s (F0-19=1) 0s ~ 65000s(F0-19=0)	

Acceleration time indicates the time required by the AC drive to accelerate from 0 Hz to "Acceleration/Deceleration base frequency" (F0-25), that is, t1 in Figure 6-1.

Deceleration time indicates the time required by the AC drive to decelerate from "Acceleration/Deceleration base frequency" (F0-25) to 0 Hz, that is, t2 in Figure 6-1.

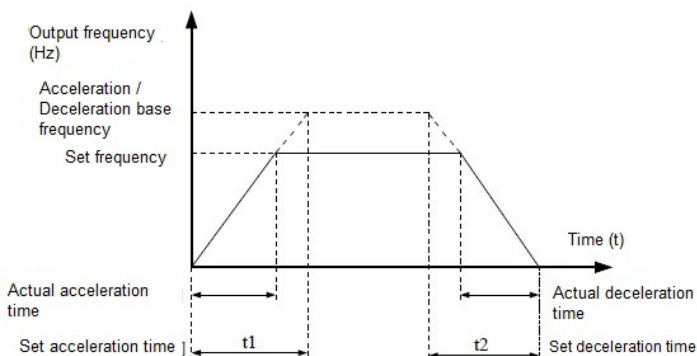

Figure 6-1 Acceleration / Deceleration time

The SINUS VEGA provides totally four groups of acceleration/deceleration time for selection. You can perform switchover by using a X terminal.

Group 1: F0-17, F0-18

Group 2: F8-03, F8-04

Group 3: F8-05, F8-06

Group 4: F8-07, F8-08

F0-19	Acceleration/Deceleration time unit		Default	1
	Setting Range	0	1s	
		1	0.1s	
		2	0.01s	

To satisfy requirements of different applications, the SINUS VEGA provides three acceleration/deceleration time units, 1s, 0.1s and 0.01s.

Note:

Modifying this Parameter will make the displayed decimal places change and corresponding acceleration/deceleration time also change.

F0-21	Frequency offset of auxiliary frequency source for X and Y operation	Default	0.00Hz
	Setting Range	0.00Hz ~ maximum frequency F0-10	

This Parameter is valid only when the frequency source is set to "X and Y operation".

The final frequency is obtained by adding the frequency offset set in this Parameter to the X and Y operation result.

F0-22	Frequency reference resolution		Default	2
	Setting Range	1	0.1Hz	
		2	0.01Hz	

It is used to set the resolution of all frequency-related Parameters.

If the resolution is 0.1 Hz, the SINUS VEGA can output up to 3200 Hz. If the resolution is 0.01 Hz, the SINUS VEGA can output up to 320.00 Hz.

Note:

Modifying this Parameter will make the decimal places of all frequency-related Parameters change and corresponding frequency values change.

F0-23	Retentive of digital setting frequency upon power failure	Default	0
	Setting Range	0	Not retentive
		1	Retentive

This Parameter is valid only when the frequency source is digital setting.

If F0-23 is set to 0, the digital setting frequency value resumes to the value of F0-08 (Preset frequency) after the AC drive stops. The modification by using keys ▲ and ▼ or the terminal UP/DOWN function is cleared.

If F0-23 is set to 1, the digital setting frequency value is the set frequency at the moment when the AC drives stops. The modification by using keys ▲ and ▼ or the terminal UP/DOWN function remains effective.

F0-24	Motor Parameter group selection	Default	0
	Setting Range	0	Motor Parameter group 1
		1	Motor Parameter group 2
		2	Motor Parameter group 3
		3	Motor Parameter group 4

The SINUS VEGA can drive four motors at different time. You can set the motor nameplate Parameters respectively, independent motor auto-tuning, different control modes, and Parameters related to running performance respectively for the four motors.

Motor Parameter group 1 corresponds to groups F1 and F2. Motor Parameter groups 2, 3 and 4 correspond to groups A2, A3 and A4 respectively.

You can select the current motor Parameter group by using F0-24 or perform switchover between the motor Parameter groups by means of a X terminal. If motor Parameters selected by means of F0-24 conflict with those selected by means of X terminal, the selection by X is preferred.

F0-25	Acceleration/Deceleration time base frequency	Default	0
	Setting Range	0	Maximum (F0-10)
		1	Set frequency
		2	100Hz

The acceleration/deceleration time indicates the time for the AC drive to increase from 0 Hz to the frequency set in F0-25. Figure 6-1 shows the acceleration/deceleration time.

If this Parameter is set to 1, the acceleration/deceleration time is related to the set frequency. If the set frequency changes frequently, the motor's acceleration/deceleration also changes.

F0-26	Base frequency for UP/DOWN modification during running	Default	0
	Setting Range	0	Running frequency
		1	Set frequency

This Parameter is valid only when the frequency source is digital setting.

It is used to set the base frequency to be modified by using keys ▲ and ▼ or the terminal UP/DOWN function. If the running frequency and set frequency are different, there will be a large difference between the AC drive's performance during the acceleration/deceleration process.

F0-27	Binding command source to frequency source		Default	000
	Setting Range	Unit's digit	Binding operation Panel command to frequency source	
		0	No binding	
		1	Frequency source by digital setting	
		2	AI1	
		3	AI2	
		4	AI3	
		5	PULSE setting (X5)	
		6	Multi-reference	
		7	Simple PLC	
		8	PID	
	9	Communication setting		
		Ten's digit	Binding terminal command to frequency source (0-9, same as unit's digit)	
	Hundred's digit	Binding communication command to frequency source (0-9, same as unit's digit)		

It is used to bind the three running command sources with the nine frequency sources, facilitating to implement synchronous switchover.

For details on the frequency sources, see the description of F0-03 (Main frequency source X selection). Different running command sources can be bound to the same frequency source.

If a command source has a bound frequency source, the frequency source set in F0-03 to F0-07 no longer takes effect when the command source is effective.

F0-28	Serial communication protocol		Default	0
	Setting Range	0	MODBUS protocol	
		1	-	
		2	-	

The SINUS VEGA supports Modbus. Select a proper protocol based on the actual requirements.

7.2 Group F1: Motor 1 Parameters

F1-00	Motor type selection	Default	0
	Setting Range	0	Common asynchronous motor
		1	Variable frequency asynchronous motor
	2	Permanent magnetic synchronous motor	
F1-01	Rated motor power	Default	Model dependent
	Setting Range	0.1kW ~ 1000.0kW	
F1-02	Rated motor voltage	Default	Model dependent
	Setting Range	1V ~ 2000V	
F1-03	Rated motor current	Default	Model dependent
	Setting Range	0.01A ~ 655.35A(AC drive power <=55kW) 0.1A ~ 6553.5A(AC drive power >55kW)	
F1-04	Rated motor frequency	Default	Model dependent
	Setting Range	0.01Hz ~ maximum frequency	
F1-05	Rated motor rotational speed	Default	Model dependent
	Setting Range	1rpm ~ 65535rpm	

Set the Parameters according to the motor nameplate, no matter whether V/F control or vector control is adopted.

To achieve better V/F or vector control performance, motor auto-tuning is required. The motor auto-tuning accuracy depends on the correct setting of motor nameplate Parameters.

F1-06	Stator resistance (asynchronous motor)	Default	Model dependent
	Setting Range	0.001Ω~ 65.535Ω(AC drive power ≤ 55kW) 0.0001Ω~ 6.5535Ω(AC drive power >55kW)	
F1-07	Rotor resistance (asynchronous motor)	Default	Model dependent
	Setting Range	0.001Ω~ 65.535Ω(AC drive power ≤ 55kW) 0.0001Ω~ 6.5535Ω(AC drive power >55kW)	
F1-08	Leakage inductive reactance (asynchronous motor)	Default	Model dependent
	Setting Range	0.01mH ~ 655.35mH(AC drive power ≤ 55kW) 0.001mH ~ 65.535mH(AC drive power >55kW)	
F1-09	Mutual inductive reactance (asynchronous motor)	Default	Model dependent
	Setting Range	0.1mH ~ 6553.5mH(AC drive power ≤ 55kW) 0.01mH ~ 655.35mH(AC drive power >55kW)	

F1-10	No-load current (asynchronous motor)	Default	Model dependent
	Setting Range	0.01A ~ F1-03(AC drive power ≤ 55kW) 0.1A ~ F1-03(AC drive power >55kW)	

The Parameters in F1-06 to P-10 are asynchronous motor Parameters. These Parameters are unavailable on the motor nameplate and are obtained by means of motor auto-tuning. Only F1-06 to F1-08 can be obtained through static motor auto-tuning. Through complete motor auto-tuning, encoder phase sequence and current loop PI can be obtained besides the Parameters in F1-06 to F1-10.

Each time "Rated motor power" (F1-01) or "Rated motor voltage" (F1-02) is changed; the AC drive automatically restores values of F1-06 to F1-10 to the Parameter setting for the common standard Y series asynchronous motor.

If it is impossible to perform motor auto-tuning onsite, manually input the values of these Parameters according to data provided by the motor manufacturer.

F1-16	Stator resistance (synchronous motor)	Default	Model dependent
	Setting Range	0.001Ω ~ 65.535Ω(AC drive power ≤ 55kW) 0.0001Ω ~ 6.5535Ω(AC drive power >55kW)	
F1-17	Shaft D inductance (synchronous motor)	Default	Model dependent
	Setting Range	0.01mH ~ 655.35mH(AC drive power ≤ 55kW) 0.001mH ~ 65.535mH(AC drive power >55kW)	
F1-18	Shaft Q inductance (synchronous motor)	Default	Model dependent
	Setting Range	0.01mH ~ 655.35mH(AC drive power ≤ 55kW) 0.001mH ~ 65.535mH(AC drive power >55kW)	
F1-20	Back EMF (synchronous motor)	Default	Model dependent
	Setting Range	0.1V ~ 6553.5V	

F1-16 to P-20 is synchronous motor Parameters. These Parameters are unavailable on the nameplate of most synchronous motors and can be obtained by means of "Synchronous motor no-load auto-tuning". Through "Synchronous motor with-load auto-tuning", only the encoder phase sequence and installation angle can be obtained.

Each time "Rated motor power" (F1-01) or "Rated motor voltage" (F1-02) is changed; the AC drive automatically modifies the values of F1-16 to F1-20.

You can also directly set the Parameters based on the data provided by the synchronous motor manufacturer.

F1-27	Encoder pulses per revolution	Default	1024
	Setting Range	1 ~ 65535	

This Parameter is used to set the pulses per revolution (PPR) of ABZ or UVW incremental encoder. In FVC mode, the motor cannot run properly if this Parameter is set incorrectly.

F1-28	Encoder type	Default	0
	Setting Range	0	ABZ incremental encoder
		1	UVW incremental encoder
		2	Resolver
		3	SIN/COS encoder
4		Wire-saving UVW encoder	

The SINUS VEGA supports multiple types of encoder. Different encoder card are required for different types of encoder. Select the appropriate encoder card for the encoder used. Any of the five encoder types is applicable to synchronous motor. Only ABZ incremental encoder and resolver are applicable to asynchronous motor.

After installation of the encoder card is complete, set this Parameter properly based on the actual condition. Otherwise, the AC drive cannot run properly

F1-30	A/B phase sequence of ABZ incremental encoder	Default	0
	Setting Range	0	Forward
		1	Reserve

This Parameter is valid only for ABZ incremental encoder (F1-28 = 0) and is used to set the A/B phase sequence of the ABZ incremental encoder

It is valid for both asynchronous motor and synchronous motor. The A/B phase sequence can be obtained through "Asynchronous motor complete auto-tuning" or "Synchronous motor no-load auto-tuning".

F1-31	Encoder installation angle	Default	0.0°
	Setting Range	0.0° ~ 359.9°	

This Parameter is applicable only to synchronous motor. It is valid for ABZ incremental encoder, UVW incremental encoder, resolver and wire-saving UVW encoder, but invalid for SIN/COS encoder.

It can be obtained through synchronous motor no-load auto-tuning or with-load auto-tuning. After installation of the synchronous motor is complete, the value of this Parameter must be obtained by motor auto-tuning. Otherwise, the motor cannot run properly.

F1-32	U, V, W phase sequence of UVW encoder		Default	0
	Setting Range	0	Forward	
		1	Reverse	
F1-33	UVW encoder angle offset		Default	0.0°
	Setting Range		0.0° ~ 359.9°	

These two Parameters are valid only when the UVW encoder is applied to a synchronous motor.

They can be obtained by synchronous motor no-load auto-tuning or with-load auto tuning. After installation of the synchronous motor is complete, the values of these two Parameters must be obtained by motor auto-tuning. Otherwise, the motor cannot run properly.

F1-34	Number of pole Pairs of resolver	Default	1
	Setting Range	1 ~ 65535	

If a resolver is applied, set the number of pole Pairs properly.

F1-36	Encoder wire-break fault detection time	Default	0.0s
	Setting Range	0.0s: No action 0.1s ~ 10.0s	

This Parameter is used to set the time that a wire-break fault lasts. If it is set to 0.0s, the AC drive does not detect the encoder wire-break fault.

If the duration of the encoder wire-break fault detected by the AC drive exceeds the time set in this Parameter, the AC drive reports Err20.

F1-37	Auto-tuning selection		Default	0
	Setting	0	No auto-tuning	
		1	Asynchronous motor static auto-tuning	
		2	Asynchronous motor complete auto-tuning	
		3	Static complete Parameter identification	
		11	Synchronous motor with-load auto-tuning	
		12	Synchronous motor no-load auto-tuning	

0: No auto-tuning, auto-tuning is prohibited.

1: Asynchronous motor static auto-tuning

It is applicable to scenarios where complete auto-tuning cannot be performed because the asynchronous motor cannot be disconnected from the load.

Before performing static auto-tuning, properly set the motor type and motor nameplate Parameters of F1-00 to F1-05 first. The AC drive will obtain Parameters of F1-06 to F1-08 by static auto-tuning.

Action specification: Set this Parameter to 1, and press the RUN key. Then, the AC drive starts static auto-tuning.

2: Asynchronous motor complete auto-tuning

To perform this type of auto-tuning, ensure that the motor is disconnected from the load. During the process of complete auto-tuning, the AC drive performs static auto-tuning first and then accelerates to 80% of the rated motor frequency within the acceleration time set in F0-17. The AC drive keeps running for a certain period and then decelerates to stop within deceleration time set in F0-18.

Before performing complete auto-tuning, properly set the motor type, motor nameplate Parameters of F1-00 to F1-05, "Encoder type" (F1-28) and "Encoder pulses per revolution" (F1-27) first.

The AC drive will obtain motor Parameters of F1-06 to F1-10, "A/B phase sequence of ABZ incremental encoder" (F1-30) and vector control current loop PI Parameters of F2-13 to F2-16 by complete auto-tuning.

Action specification: Set this Parameter to 2, and press the RUN key. Then, the AC drive starts complete auto tuning.

3: Static complete Parameter identification

Suitable for no encoder, motor under stationary state to complete motor Parameter self learning (the motor may be still slight shaking, need to Pay attention to safety).

Before complete asynchronous machine static tuning, the motor type and motor nameplate Parameter F1-00 ~ F1-05 must be set properly. After complete asynchronous machine static tuning, frequency inverter can get F1-06 ~ F1-10 five Parameters

11: Synchronous motor with-load auto-tuning

It is applicable to scenarios where the synchronous motor cannot be disconnected from the load. During with-load auto-tuning, the motor rotates at the speed of 10 PRM.

Before performing with-load auto-tuning, properly set the motor type and motor nameplate Parameters of F1-00 to F1-05 first.

By with-load auto-tuning, the AC drive obtains the initial position angle of the synchronous motor, which is a necessary prerequisite of the motor's normal running.

Before the first use of the synchronous motor after installation, motor auto-tuning must be performed.

Action specification: Set this Parameter to 11, and press the RUN key. Then, the AC drive starts with-load auto-tuning.

12: Synchronous motor no-load auto-tuning

If the synchronous motor can be disconnected from the load, no-load auto-tuning is recommended, which will achieve better running performance compared with with-load auto-tuning.

During the process of no-load auto-tuning, the AC drive performs with-load auto-tuning first and then accelerates to 80% of the rated motor frequency within the acceleration time set in F0-17. The AC drive keeps running for a certain period and then decelerates to stop within the deceleration time set in F0-18

Before performing no-load auto-tuning, properly set the motor type, motor nameplate Parameters of F1-00 to F1-05, "Encoder type" (F1-28) and "Encoder pulses per revolution" (F1-27) and "Number of pole Pairs of resolver" (F1-34) first.

The AC drive will obtain motor Parameters of F1-16 to F1-20, encoder related Parameters of F1-30 to F1-33 and vector control current loop PI Parameters of F2-13 to F2-16 by no-load auto-tuning.

Action specification: Set this Parameter to 12, and press the RUN key. Then, the AC drive starts no-load auto-tuning.

Note: Motor auto-tuning can be performed only in operation Panel mode.

7.3 Group F2: Vector Control Parameters

Group F2 is valid for vector control, and invalid for V/F control.

F2-00	Speed loop proportional gain 1	Default	30
	Setting Range	1 ~ 100	
F2-01	Speed loop integral time 1	Default	0.50s
	Setting Range	0.01s ~ 10.00s	
F2-02	Switchover frequency 1	Default	5.00Hz
	Setting Range	0.00 ~ F2-05	

F2-03	Speed loop proportional gain 2	Default	20
	Setting Range	0 ~ 100	
F2-04	Speed loop integral time 2	Default	1.00s
	Setting Range	0.01s ~ 10.00s	
F2-05	Switchover frequency 2	Default	10.00Hz
	Setting Range	F2-02 ~ maximum output frequency	

Speed loop PI Parameters vary with running frequencies of the AC drive.

If the running frequency is less than or equal to "Switchover frequency 1" (F2-02), the speed loop PI Parameters are F2-00 and F2-01.

If the running frequency is equal to or greater than "Switchover frequency 2" (F2-05), the speed loop PI Parameters are F2-03 and F2-04.

If the running frequency is between F2-02 and F2-05, the speed loop PI Parameters are obtained from the linear switchover between the two groups of PI Parameters, as shown in Figure 6-2.

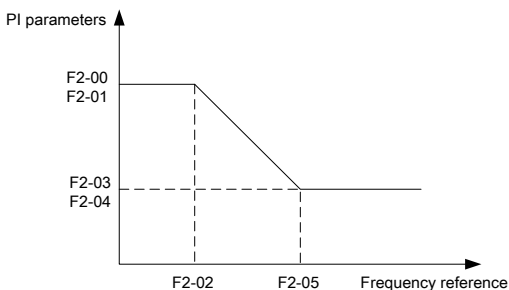

Figure 6-2: Relationship between running frequencies and PI Parameters

The speed dynamic response characteristics in vector control can be adjusted by setting the proportional gain and integral time of the speed regulator.

To achieve a faster system response, increase the proportional gain and reduce the integral time. Be aware that this may lead to system oscillation.

The recommended adjustment method is as follows:

If the factory setting cannot meet the requirements, make proper adjustment. Increase the proportional gain first to ensure that the system does not oscillate, and then reduce the integral time to ensure that the system has quick response and small overshoot.

Note: Improper PI Parameter setting may cause too large speed overshoot, and over voltage fault may even occur when the overshoot drops.

F2-06	Vector control slip gain	Default	100%
	Setting Range	50% ~ 200%	

For SVC, it is used to adjust speed stability accuracy of the motor. When the motor with load runs at a very low speed, increase the value of this Parameter; when the motor with load runs at a very large speed, decrease the value of this Parameter.

For FVC, it is used to adjust the output current of the AC drive with same load.

F2-07	Time constant of speed loop filter	Default	0.000s
	Setting Range	0.000s ~ 0.100s	

In the vector control mode, the output of the speed loop regulator is torque current reference. This Parameter is used to filter the torque references. It need not be adjusted generally and can be increased in the case of large speed fluctuation. In the case of motor oscillation, decrease the value of this Parameter properly.

If the value of this Parameter is small, the output torque of the AC drive may fluctuate greatly, but the response is quick.

F2-08	Vector control over-excitation gain	Default	64
	Setting Range	0 ~ 200	

During deceleration of the AC drive, over-excitation control can restrain rise of the bus voltage to avoid the over voltage fault. The larger the over-excitation gain is, the better the restraining effect is.

Increase the over-excitation gain if the AC drive is liable to over voltage error during deceleration. Too large over-excitation gain, however, may lead to an increase in output current. Therefore, set this Parameter to a proper value in actual applications.

Set the over-excitation gain to 0 in applications of small inertia (the bus voltage will not rise during deceleration) or where there is a braking resistor.

F2-09	Torque upper limit source in speed control mode		Default	0
	Setting Range	0	F2-10	
		1	AI1	
		2	AI2	
		3	AI3	
		4	PULSE setting (X5)	
		5	Communication setting	

F2-10	Digital setting of torque upper limit in speed control mode	Default	150.0%
	Setting Range	0.0% ~ 200.0%	

In the speed control mode, the maximum output torque of the AC drive is restricted by F2-09.

If the torque upper limit is analog, pulse or communication setting, 100% of the setting corresponds to the value of F2-10, and 100% of the value of F2-10 corresponds to the AC drive rated torque.

F2-13	Excitation adjustment proportional gain	Default	2000
	Setting Range	0 ~ 20000	
F2-14	Excitation adjustment integral gain	Default	1300
	Setting Range	0 ~ 20000	
F2-15	Torque adjustment proportional gain	Default	2000
	Setting Range	0 ~ 20000	
F2-16	Torque adjustment integral gain	Default	1300
	Setting Range	0 ~ 20000	

These are current loop PI Parameters for vector control. These Parameters are automatically obtained through "Asynchronous motor complete auto-tuning" or "Synchronous motor no-load auto-tuning", and do not need to be modified.

The dimension of the current loop integral regulator is integral gain rather than integral time.

Note that too large current loop PI gain may lead to oscillation of the entire control loop.

Therefore, when current oscillation or torque fluctuation is great, manually decrease the proportional gain or integral gain here.

F2-18	Field weakening mode of synchronous motor		Default	0
	Setting Range	0	No field weakening	
		1	Direct calculation	
		2	Automatic adjustment	
F2-19	Field weakening depth of synchronous motor		Default	100%
	Setting Range		50% ~ 500%	

F2-20	Maximum field weakening current	Default	50%
	Setting Range	1% ~ 300%	
F2-21	Field weakening automatic adjustment gain	Default	100%
	Setting Range	10% ~ 500%	
F2-22	Field weakening integral multiple	Default	2
	Setting Range	2 ~ 10	

These Parameters are used to set field weakening control for the synchronous motor.

If F2-18 is set to 0, field weakening control on the synchronous motor is disabled. In this case, the maximum rotational speed is related to the AC drive bus voltage. If the motor's maximum rotational speed cannot meet the requirements, enable the field weakening function to increase the speed.

The SINUS VEGA provides two field weakening modes: direct calculation and automatic adjustment.

In direct calculation mode, directly calculate the demagnetized current and manually adjust the demagnetized current by means of F2-19. The smaller the demagnetized current is, the smaller the total output current is. However, the desired field weakening effect may not be achieved.

In automatic adjustment mode, the best demagnetized current is selected automatically. This may influence the system dynamic performance or cause instability.

The adjustment speed of the field weakening current can be changed by modifying the values of F2-21 and F2-22. A very quick adjustment may cause instability. Therefore, generally do not modify them manually.

7.4 Group F3: V/F Control Parameters

Group F3 is only valid for VF control.

The VF control mode is applicable to low load applications (fan or pump) or applications where one AC drive operates multiple motors or there is a large difference between the AC drive power and the motor power.

F3-00	V/F curve setting	Default	0
	Setting Range	0	Linear VF
		1	Multi-point VF
		2	Square VF
		3	1.2-power VF
		4	1.4-power VF
		6	1.6-power VF
		8	1.8-power VF
		9	Reserved
		10	VF complete separation
		11	VF half separation

0: Linear V/F. It is applicable to common constant torque load.

1: Multi-point VF. It is applicable to special load such as dehydrator and centrifuge. Any such VF curve can be obtained by setting Parameters of F3-03 to F3-08.

2: Square VF. It is applicable to centrifugal loads such as fan and pump.

3~8: VF curve between linear VF and square VF

10: VF complete separation. In this mode, the output frequency and output voltage of the AC drive are independent. The output frequency is determined by the frequency source, and the output voltage is determined by "Voltage source for VF separation" (F3-13).

It is applicable to induction heating, inverse power supply and torque motor control.

11: VF half separation

In this mode, V and F are proportional and the proportional relationship can be set in F3-13. The relationship between V and F are also related to the rated motor voltage and rated motor frequency in Group F1.

Assume that the voltage source input is X (0 to 100%), the relationship between V and F is:

$$V/F = 2 \times X \times (\text{Rated motor voltage}) / (\text{Rated motor frequency})$$

F3-01	Torque boost	Default	Model dependent
	Setting Range	0.0% ~ 30%	

F3-02	Cut-off frequency of torque boost	Default	50.00Hz
	Setting Range	0.00Hz ~ maximum output frequency	

To compensate the low frequency torque characteristics of V/F control, you can boost the output voltage of the AC drive at low frequency by modifying F3-01. If the torque boost is set to too large, the motor may overheat, and the AC drive may suffer over current.

If the load is large and the motor startup torque is insufficient, increase the value of F3-01.

If the load is small, decrease the value of F3-01. If it is set to 0.0, the AC drive performs automatic torque boost. In this case, the AC drive automatically calculates the torque boost value based on motor Parameters including the stator resistance.

F3-02 specifies the frequency under which torque boost is valid. Torque boost becomes invalid when this frequency is exceeded, as shown in the following figure 6-3.

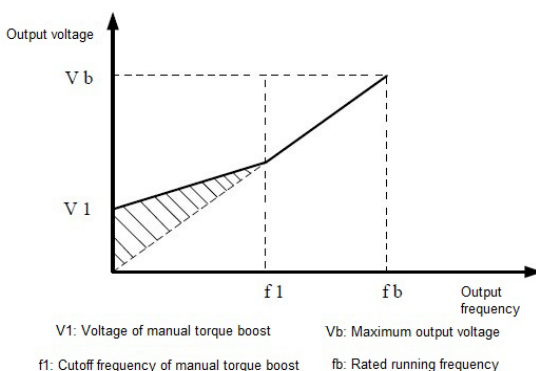

Figure 6-3 Manual torque boost

F3-03	Multi-point VF frequency F1	Default	0.00Hz
	Setting Range	0.00Hz ~ F3-05	
F3-04	Multi-point VF voltage V1	Default	0.0%
	Setting Range	0.0% ~ 100.0%	
F3-05	Multi-point VF frequency F2	Default	0.00Hz
	Setting Range	F3-03 ~ F3-07	

F3-06	Multi-point VF voltage V2	Default	0.0%
	Setting Range	0.0% ~ 100.0%	
F3-07	Multi-point VF frequency F3	Default	0.00Hz
	Setting Range	F3-05 ~ rated motor frequency (F1-04) Note: The rated frequencies of motors 2, 3, and 4 are respectively set in A2-04, A3-04, and A4-04	
F3-08	Multi-point VF voltage V3	Default	0.0%
	Setting Range	0.0% ~ 100.0%	

These six Parameters are used to define the multi-point VF curve.

The multi-point VF curve is set based on the motor's load characteristic. The relationship between voltages and frequencies is:

$$V1 < V2 < V3, F1 < F2 < F3$$

At low frequency, higher voltage may cause overheat or even burnt out of the motor and over current stall or over current protection of the AC drive.

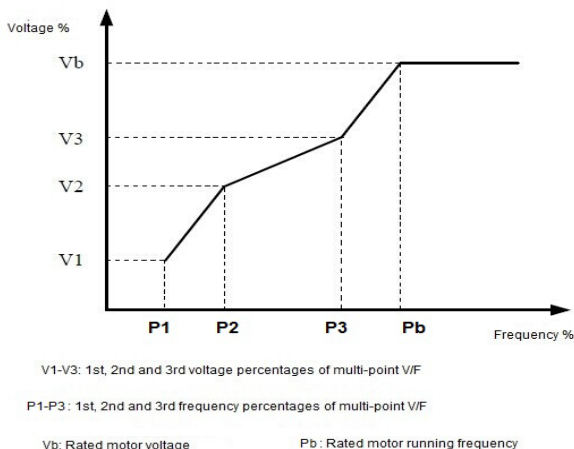

Figure 6-4 Setting of multi-point VF curve

F3-09	VF slip compensation gain	Default	0.0%
	Setting Range	0% ~ 200.0%	

This Parameter is valid only for the asynchronous motor.

It can compensate the rotational speed slip of the asynchronous motor when the load of the motor increases, stabilizing the motor speed in case of load change.

If this Parameter is set to 100%, it indicates that the compensation when the motor bears rated load is the rated motor slip. The rated motor slip is automatically obtained by the AC drive through calculation based on the rated motor frequency and rated motor rotational speed in group F1.

Generally, if the motor rotational speed is different from the target speed, slightly adjust this Parameter.

F3-10	VF over-excitation gain	Default	64
	Setting	0 ~ 200	

During deceleration of the AC drive, over-excitation can restrain rise of the bus voltage, preventing the over voltage fault. The larger the over-excitation is, the better the restraining result is.

Increase the over-excitation gain if the AC drive is liable to over voltage error during deceleration. However, too large over-excitation gain may lead to an increase in the output current. Set F3-09 to a proper value in actual applications.

Set the over-excitation gain to 0 in the applications where the inertia is small and the bus voltage will not rise during motor deceleration or where there is a braking resistor.

F3-11	VF oscillation suppression gain	Default	Model dependent
	Setting Range	0 ~ 100	

Set this Parameter to a value as small as possible in the prerequisite of efficient oscillation suppression to avoid influence on VF control.

Set this Parameter to 0 if the motor has no oscillation. Increase the value properly only when the motor has obvious oscillation. The larger the value is, the better the oscillation suppression result will be.

When the oscillation suppression function is enabled, the rated motor current and no-load current must be correct. Otherwise, the VF oscillation suppression effect will not be satisfactory.

F3-13	VF Voltage source for VF separation	Default	0
	Setting Range	0	Digital setting (F3-14)
		1	AI1
		2	AI2
		3	AI3

		4	PULSE setting (X5)
		5	Multi-reference
		6	Simple PLC
		7	PID
		8	Communication setting
		100.0% corresponds to the rated motor voltage (F1-02)	

VF separation is generally applicable to scenarios such as induction heating, inverse power supply and motor torque control.

If VF separated control is enabled, the output voltage can be set in F3-14 or by means of analog, multi-reference, simple PLC, PID or communication. If you set the output voltage by means of non-digital setting, 100% of the setting corresponds to the rated motor voltage. If a negative percentage is set, its absolute value is used as the effective value.

0: Digital setting (F3-14)

The output voltage is set directly in F3-14.

1: AI1 2: AI2 3: AI3

The output voltage is set by AI1 terminals.

4: PULSE setting (X5)

The output voltage is set by pulses of the terminal X5.

Pulse setting specification: voltage range 9–30 V, frequency range 0–100 kHz

5: Multi-reference

If the voltage source is multi-reference, Parameters in group F4 and FC must be set to determine the corresponding relationship between setting signal and setting voltage.

6: Simple PLC

If the voltage source is simple PLC mode, Parameters in group FC must be set to determine the setting output voltage.

7: PID

The output voltage is generated based on PID closed loop. For details, see the description of PID in group FA.

8: Communication setting

The output voltage is set by the host computer by means of communication.

When the voltage source to choose 1 ~ 8, 0 ~ 100% are corresponding to the output voltage of 0 V ~ motor rated voltage.

F3-14	VF Separation of digital voltage setting	Default	0V
	Setting Range	0V ~ Motor Rated Voltage	
F3-15	Voltage rise time of VF separation	Default	0.0s
	Setting Range	0.0s ~ 1000.0s	
F3-16	Voltage decline time of VF separation	Default	0.0s
	Setting Range	0.0s ~ 1000.0s	

The voltage source for VF separation is set in the same way as the frequency source. For details, see F0-03. 100.0% of the setting in each mode corresponds to the rated motor voltage. If the corresponding value is negative, its absolute value is used

F3-15 indicates the time required for the output voltage to rise from 0 V to the rated motor voltage shown as t_1 in the following figure.

F3-16 indicates the time required for the output voltage to decline from the rated motor voltage to 0 V, shown as t_2 in the following figure.

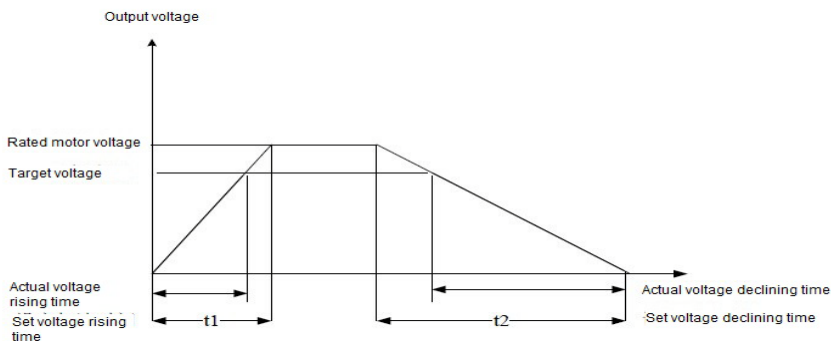

Figure 6-5 Voltage of V/F separation

7.5 Group F4: Input Terminals

The SINUS VEGA provides seven X terminals (X5 can be used for high-speed pulse input) and two analog input (AI) terminals. The optional extension card provides another seven X terminals (X6 to X10) and an AI terminal (AI3).

Function Code	Parameter Name	Default	Remark
F4-00	X1 function selection	1: Forward RUN (FWD)	Standard
F4-01	X2 function selection	2: Reverse RUN(REV)	Standard
F4-02	X3 function selection	4: Forward JOG (FJOG)	Standard
F4-03	X4 function selection	9: Fault reset (RESET)	Standard
F4-04	X5 function selection	12: Multi-reference terminal 1	Standard
F4-05	X6 function selection	13: Multi-reference terminal 2	Standard
F4-06	X7 function selection	0	Standard
F4-07	Reserved	-	-
F4-08	Reserved	-	-
F4-09	Reserved	-	-

The following table lists the functions available for the X terminals.

Value	Function	Description
0	No function	Set 0 for reserved terminals to avoid malfunction.
1	Forward RUN (FWD)	The terminal is used to control forward or reverse RUN of the AC drive.
2	Reverse RUN (REV)	
3	Three-line control	The terminal determines three-line control of the AC drive. For details, see the description of F4-11.
4	Forward JOG (FJOG)	FJOG indicates forward JOG running, while RJOG indicates reverse JOG running. The JOG frequency, acceleration time and deceleration time are described respectively in F8-00, F8-01 and F8-02.
5	Reverse JOG (RJOG)	
6	Terminal UP	If the frequency is determined by external terminals, the terminals with the two functions are used as increment and decrement commands for frequency modification. When the frequency source is digital setting, they are used to adjust the frequency.
7	Terminal DOWN	
8	Coast to stop	The AC drive blocks its output, the motor coasts to rest and is not controlled by the AC drive. It is the same as coast to stop described in F6-10.
9	Fault reset (RESET)	The terminal is used for fault reset function, the same as the function of RESET key on the operation Panel. Remote fault reset is implemented by this function.
10	RUN Pause	The AC drive decelerates to stop, but the running Parameters are all memorized, such as PLC, swing frequency and PID Parameters. After this function is disabled, the AC drive resumes its status before stop.
11	Normally open (NO) input of external fault	If this terminal becomes ON, the AC drive reports Err15 and performs the fault protection action. For more details, see the description of F9-47.

Value	Function	Description
12	Multi-reference terminal 1	The setting of 16 speeds or 16 other references can be implemented through combinations of 16 states of these four terminals. For more details, see appendix 1.
13	Multi-reference terminal 2	
14	Multi-reference terminal 3	
15	Multi-reference terminal 4	
16	Terminal 1 for acceleration/deceleration time selection	Totally four groups of acceleration/deceleration time can be selected through combinations of two states of these two terminals. For more details, see appendix 2.
17	Terminal 2 for acceleration/deceleration time selection	
18	Frequency source switchover	The terminal is used to perform switchover between two frequency sources according to the setting in F0-07.
19	UP/DOWN setting clear (terminal, operation Panel)	If the frequency source is digital setting, the terminal is used to clear the modification by using the UP/DOWN function or the increment/decrement key on the operation Panel, returning the set frequency to the value of F0-08.
20	Command source switchover terminal	If the command source is set to terminal control (F0-02 = 1), this terminal is used to perform switchover between terminal control and operation Panel control. If the command source is set to communication control (F0-02 = 2), this terminal is used to perform switchover between communication control and operation Panel control.
21	Acceleration/Deceleration prohibited	It enables the AC drive to maintain the current frequency output without being affected by external signals (except the STOP command).
22	PID Pause	PID is invalid temporarily. The AC drive maintains the current frequency output without supporting PID adjustment of frequency source.
23	PLC Pause	The terminal is used to restore the original status of PLC control for the AC drive when PLC control is started again after a Pause.
24	Swing Pause	The AC drive outputs the central frequency, and the swing frequency function Pauses.
25	Counter input	This terminal is used to count pulses.
26	Counter reset	This terminal is used to clear the counter status.
27	Length count input	This terminal is used to count the length.
28	Length reset	This terminal is used to clear the length.
29	Torque control prohibited	The AC drive is prohibited from torque control and enters the speed control mode.
30	Pulse input (enabled only for X5)	X5 is used for pulse input.
31	Reserved	Reserved

Value	Function	Description
32	Immediate DC braking	After this terminal becomes ON, the AC drive directly switches over to the DC braking state.
33	Normally closed (NC) input of external fault	After this terminal becomes ON, the AC drive reports Err15 and stops.
34	Frequency modification forbidden	After this terminal becomes ON, the AC drive does not respond to any frequency modification.
35	Reverse PID action direction	After this terminal becomes ON, the PID action direction is reversed to the direction set in FA-03.
36	External STOP terminal 1	In operation Panel mode, this terminal can be used to stop the AC drive, equivalent to the function of the STOP key on the operation Panel.
37	Command source switchover terminal 2	It is used to perform switchover between terminal control and communication control. If the command source is terminal control, the system will switch over to communication control after this terminal becomes ON.
38	PID integral Pause	After this terminal becomes ON, the integral adjustment function Pauses. However, the proportional and differentiation adjustment functions are still valid.
39	Switchover between main frequency source X and preset frequency	After this terminal becomes ON, the frequency source X is replaced by the preset frequency set in F0-08.
40	Switchover between auxiliary frequency source Y and preset frequency	After this terminal is enabled, the frequency source Y is replaced by the preset frequency set in F0-08.
41	Motor selection terminal 1	Switchover among the four groups of motor Parameters can be implemented through the four state combinations of these two terminals. For more details, see appendix 3.
42	Motor selection terminal 2	
43	PID Parameter switchover	If the PID Parameters switchover performed by means of X terminal (FA-18 = 1), the PID Parameters are FA-05 to FA-07 when the terminal becomes OFF; the PID Parameters are FA-15 to FA-17 when this terminal becomes ON.
44	User-defined fault 1	If these two terminals become ON, the AC drive reports Err27 and Err28 respectively, and performs fault protection actions based on the setting in F9-49.
45	User-defined fault 2	
46	Speed control / Torque control switchover	This terminal enables the AC drive to switch over between speed control and torque control. When this terminal becomes OFF, the AC drive runs in the mode set in A0-00. When this terminal becomes ON, the AC drive switches over to the other control mode.

Value	Function	Description
47	Emergency stop	When this terminal becomes ON, the AC drive stops within the shortest time. During the stop process, the current remains at the set current upper limit. This function is used to satisfy the requirement of stopping the AC drive in emergency state.
48	External STOP terminal 2	In any control mode (operation Panel, terminal or communication), it can be used to make the AC drive decelerate to stop. In this case, the deceleration time is deceleration time 4.
49	Deceleration DC braking	When this terminal becomes ON, the AC drive decelerates to the initial frequency of stop DC braking and then switches over to DC braking state.
50	Clear the current running time	When this terminal becomes ON, the AC drive's current running time is cleared. This function must be supported by F8-42 and F8-53.

Appendix 1: State combinations of the four multi-reference terminals

The four multi-reference terminals have 16 state combinations, corresponding to 16 reference values, as listed in the following table:

K4	K3	K2	K1	Reference Setting	Corresponding Parameter
OFF	OFF	OFF	OFF	Reference 0	FC-00
OFF	OFF	OFF	ON	Reference 1	FC-01
OFF	OFF	ON	OFF	Reference 2	FC-02
OFF	OFF	ON	ON	Reference 3	FC-03
OFF	ON	OFF	OFF	Reference 4	FC-04
OFF	ON	OFF	ON	Reference 5	FC-05
OFF	ON	ON	OFF	Reference 6	FC-06
OFF	ON	ON	ON	Reference 7	FC-07
ON	OFF	OFF	OFF	Reference 8	FC-08
ON	OFF	OFF	ON	Reference 9	FC-09
ON	OFF	ON	OFF	Reference 10	FC-10
ON	OFF	ON	ON	Reference 11	FC-11
ON	ON	OFF	OFF	Reference 12	FC-12

K4	K3	K2	K1	Reference Setting	Corresponding Parameter
ON	ON	OFF	ON	Reference 13	FC-13
ON	ON	ON	OFF	Reference 14	FC-14
ON	ON	ON	ON	Reference 15	FC-15

If the frequency source is multi-reference, the value 100% of FC-00 to FC-15 corresponds to the value of F0-10 (Maximum frequency).

Besides the multi-speed function, the multi-reference can be also used as the PID setting source or the voltage source for VF separation, satisfying the requirement on switchover of different setting values.

Appendix 2: State combinations of two terminals for acceleration/deceleration time selection

Terminal 2	Terminal 1	Acceleration/Deceleration Time Selection	Corresponding Parameters
OFF	OFF	Acceleration/Deceleration time 1	F0-17、 F0-18
OFF	ON	Acceleration/Deceleration time 2	F8-03、 F8-04
ON	OFF	Acceleration/Deceleration time 3	F8-05、 F8-06
ON	ON	Acceleration/Deceleration time 4	F8-07、 F8-08

Appendix 3: State combinations of two motor selection terminals

Terminal 2	Terminal 1	Selected Motor	Corresponding Parameters
OFF	OFF	Motor 1	Group F1, F2
OFF	ON	Motor 2	Group A2
ON	OFF	Motor 3	Group A3
ON	ON	Motor 4	Group A4
F4-10	X filter time	Default	0.010s
	Setting Range	0.000s ~ 1.000s	

It is used to set the software filter time of X terminal status. If X terminals are liable to interference and may cause malfunction, increase the value of this Parameter to enhance the anti-interference capability. However, increase of X filter time will reduce the response of X terminals.

F4-11	Terminal command mode	Default	0
	Setting Range	0	Two-line mode 1
		1	Two-line mode 2
		2	Three-line mode 1
		3	Three-line mode 2

This Parameter is used to set the mode in which the AC drive is controlled by external terminals.

0: Two-line mode 1: It is the most commonly used two-line mode, in which the forward/reverse rotation of the motor is decided by X1 and X2. The Parameters are set as below:

Function Code	Parameter Name	Value	Function Description
F4-11	Terminal command mode	0	Two-line 1
F4-00	X1 function selection	1	Forward RUN (FWD)
F4-01	X2 function selection	2	Reverse RUN (REV)

K1	K2	Run command
1	0	Forward RUN
0	1	Reverse RUN
1	1	Stop
0	0	Stop

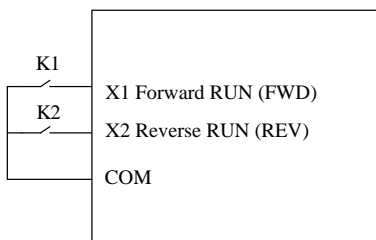

Figure 6-6 Setting of two-line mode 1

1: Two-line mode 2

In this mode, X1 is RUN enabled terminal, and X2 determines the running direction.

The Parameters are set as below:

Function Code	Parameter Name	Value	Function Description
F4-11	Terminal command mode	1	Two-line 2
F4-00	X1 function selection	1	RUN enabled
F4-01	X2 function selection	2	Forward or reverse direction

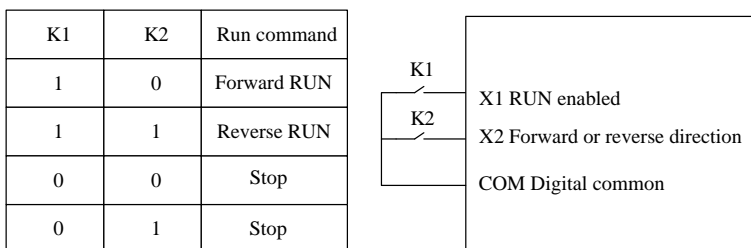

Figure 6-7 Setting of two-line mode 2

As shown in the preceding figure, if K1 is ON, the AC drive instructs forward rotation when K2 is OFF, and instructs reverse rotation when K2 is ON. If K1 is OFF, the AC drive stops.

2: Three-line mode 1

In this mode, X3 is RUN enabled terminal, and the direction is decided by X1 and X2.

The Parameters are set as below:

Function Code	Parameter Name	Value	Function Description
F4-11	Terminal command mode	2	Three-line 1
F4-00	X1 function selection	1	Forward RUN (FWD)
F4-01	X2 function selection	2	Reverse RUN (REV)
F4-02	X3 function selection	3	Three-line control

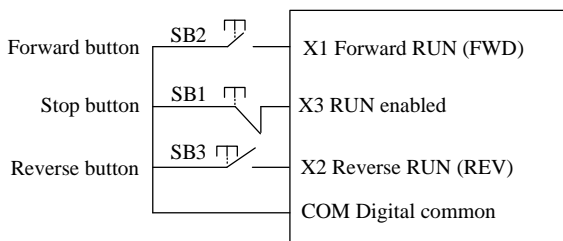

Figure 6-8 Setting of three-line mode 1

As shown in the preceding figure, if SB1 is ON, the AC drive instructs forward rotation when SB2 is pressed to be ON and instructs reverse rotation when SB3 is pressed to be ON. The AC drive stops immediately after SB1 becomes OFF. During normal startup and running, SB1 must remain ON. The AC drive's running state is determined by the final actions on SB1, SB2 and SB3.

3: Three-line mode 2

In this mode, X3 is RUN enabled terminal. The RUN command is given by X1 and the direction is decided by X2. The Parameters are set as below:

Function Codes are set as below:

Function Code	Parameter Name	Value	Function Description
F4-11	Terminal command mode	3	Three-line 2
F4-00	X1 function selection	1	RUN enabled
F4-01	X2 function selection	2	Forward or reverse direction
F4-02	X3 function selection	3	Three-line control

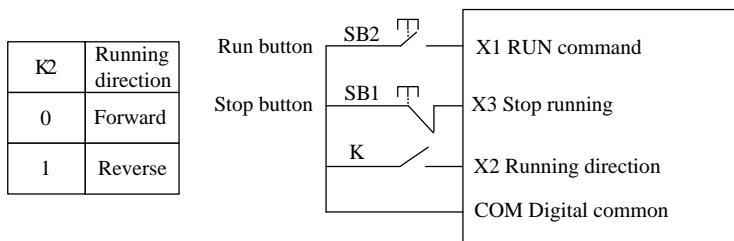

Figure 6-9 Setting of three-line mode 2

As shown in the preceding figure, if SB1 is ON, the AC drive starts running when SB2 is pressed to be ON; the AC drive instructs forward rotation when K is OFF and instructs reverse rotation when K is ON. The AC drive stops immediately after SB1 becomes OFF. During normal startup and running, SB1 must remain ON. The AC drive's running state is determined by the final actions of SB1, SB2 and K.

F4-12	Terminal UP/DOWN rate	Default	1.00Hz/s
	Setting Range	0.01Hz/s ~ 65.535Hz/s	

It is used to adjust the rate of change of frequency when the frequency is adjusted by means of terminal UP/DOWN.

If F0-22 (Frequency reference resolution) is 2, the setting range is 0.001–65.535 Hz/s.

If F0-22 (Frequency reference resolution) is 1, the setting range is 0.01–655.35 Hz/s.

F4-13	All curve 1 minimum input	Default	0.00V
	Setting Range	0.00V ~ F4-15	

F4-14	Corresponding setting of AI1 curve 1 minimum input	Default	0.0%
	Setting Range	-100.00% ~ 100.0%	
F4-15	AI1 curve 1 maximum input	Default	10.00V
	Setting Range	F4-13 ~ 10.00V	
F4-16	Corresponding setting of AI1 curve 1 maximum input	Default	100.0%
	Setting Range	-100.00% ~ 100.0%	
F4-17	AI1 filter time	Default	0.10s
	Setting Range	0.00s ~ 10.00s	

These Parameters are used to define the relationship between the analog input voltage and the corresponding setting.

When the analog input voltage exceeds the maximum value (F4-15), the maximum value is used.

When the analog input voltage is less than the minimum value (F4-13), the value set in F4-34 (Setting for AI1 less than minimum input) is used.

When the analog input is current input, 1 mA current corresponds to 0.5 V voltages.

F4-17 (AI1 filter time) is used to set the software filter time of AI1. If the analog input is liable to interference, increase the value of this Parameter to stabilize the detected analog input. However, increase of the AI filter time will slow the response of analog detection. Set this Parameter properly based on actual conditions.

In different applications, 100% of analog input corresponds to different nominal values. For details, refer to the description of different applications.

Two typical setting examples are shown in the following figure.

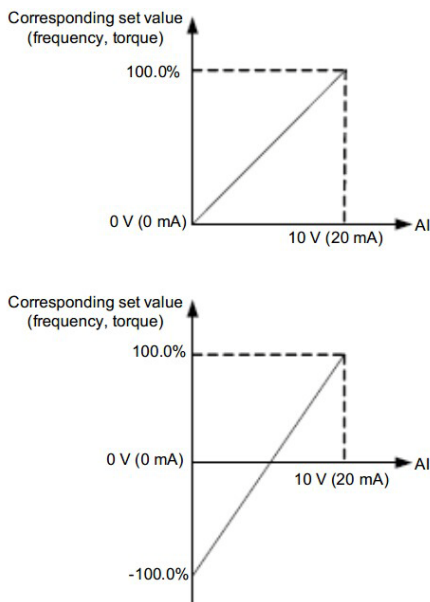

Figure 6-10 Corresponding relationship between analog input and set values

F4-18	AI2 curve minimum input	Default	0.00V
	Setting Range	0.00V ~ F4-20	
F4-19	Corresponding setting of AI2 curve minimum input	Default	0.0%
	Setting Range	-100.00% ~ 100.0%	
F4-20	AI2 curve maximum input	Default	10.00V
	Setting Range	F4-18 ~ 10.00V	
F4-21	Corresponding setting of AI2 curve maximum input	Default	100.0%
	Setting Range	-100.00% ~ 100.0%	
F4-22	AI2 filter time	Default	0.10s
	Setting Range	0.00s ~ 10.00s	

The method of setting AI2S functions is similar to that of setting AI1 function.

F4-23	AI1 curve 2 minimum input	Default	0.00V
	Setting Range	0.00s ~ F4-25	
F4-24	Corresponding setting of AI1 curve 2 minimum input	Default	0.0%
	Setting Range	-100.00% ~ 100.0%	
F4-25	AI1 curve 2 maximum input	Default	10.00V
	Setting Range	F4-23 ~ 10.00V	
F4-26	Corresponding setting of AI1 curve 2 maximum input	Default	100.0%
	Setting Range	-100.00% ~ 100.0%	
F4-27	AI3 filter time	Default	0.10s
	Setting Range	0.00s ~ 10.00s	

The method of setting AI1 2 functions is similar to that of setting AI1 function.

F4-28	PULSE minimum input	Default	0.00kHz
	Setting Range	0.00kHz ~ F4-30	
F4-29	Corresponding setting of pulse minimum input	Default	0.0%
	Setting Range	-100.00% ~ 100.0%	
F4-30	Pulse maximum input	Default	50.00kHz
	Setting Range	F4-28 ~ 50.00kHz	
F4-31	Corresponding setting of pulse maximum input	Default	100.0%
	Setting Range	-100.00% ~ 100.0%	
F4-32	PULSE filter time	Default	0.10s
	Setting Range	0.00s ~ 10.00s	

These Parameters are used to set the relationship between X5 pulse input and corresponding settings. The pulses can only be input by X5. The method of setting this function is similar to that of setting AI1 function.

F4-33	AI1 curve selection		Default	321
	Setting Range	Unit's digit	AI1 curve selection	
		1	Curve 1 (2 points, see F4-13 ~ F4-16)	
		2	Curve 2 (2 points, see F4-18 ~ F4-21)	
		3	Curve 3 (2 points, see F4-23 ~ F4-26)	
		4	Curve 4 (4 points, see A6-00 ~ A6-07)	
		5	Curve 5 (4 points, see A6-08 ~ A6-15)	
		Ten's digit	AI2 curve selection (1 ~ 5, same to AI1)	
Hundred's digit	AI3 curve selection (1 ~ 5, same to AI1)			

The unit's digit, ten's digit and hundred's digit of this Parameter are respectively used to select the corresponding curve of AI1, AI2 and AI3. Any of the five curves can be selected for AI1, AI2 and AI3.

Curve 1, curve 2 and curve 3 are all 2-point curves, set in group F4. Curve 4 and curve 5 are both 4-point curves, set in group A6.

The SINUS VEGA provides two AI terminals as standard. AI3 is provided by an optional extension card.

F4-34	Setting for AI1 less than minimum input		Default	000
	Setting Range	Unit's digit	Setting for AI1 less than minimum input	
		0	Minimum value	
		1	0.0%	
		Ten's digit	Setting for AI2 less than minimum input (0 ~ 1, same to AI1)	
		Hundred's digit	Setting for AI3 less than minimum input (0 ~ 1, same to AI1)	

This Parameter is used to determine the corresponding setting when the analog input voltage is less than the minimum value. The unit's digit, ten's digit and hundred's digit of this Parameter respectively correspond to the setting for AI3, AI2 and AI1.

If the value of a certain digit is 0, when analog input voltage is less than the minimum input, the corresponding setting of the minimum input (F4-14, F4-19, F4-24) is used.

If the value of a certain digit is 1, when analog input voltage is less than the minimum input, the corresponding value of this analog input is 0.0%.

F4-35	X1 delay time	Default	0.0s
	Setting Range	0.0s ~ 3600.0s	
F4-36	X2 delay time	Default	0.0s
	Setting Range	0.0s ~ 3600.0s	
F4-37	X3 delay time	Default	0.0s
	Setting Range	0.0s ~ 3600.0s	

These Parameters are used to set the delay time of the AC drive when the status of X terminals changes. Currently, only X1, X2 and X3 support the delay time function.

F4-38	X valid mode selection 1		Default	00000
	Setting Range	Unit's digit	X1 valid mode	
		0	High level valid	
		1	Low level valid	
		Ten's digit	X2 valid mode (0 ~ 1, same as X1)	
		Hundred's digit	X3 valid mode (0 ~ 1, same as X1)	
		Thousand's digit	X4 valid mode (0 ~ 1, same as X1)	
		Ten thousand's digit	X5 valid mode (0 ~ 1, same as X1)	
F4-39	X valid mode selection 2		Default	00000
	Setting Range	Unit's digit	X6 valid mode	
		0	High level valid	
		1	Low level valid	
		Ten's digit	X7 valid mode (0 ~ 1, same as X1)	
		Hundred's digit	X8 valid mode (0 ~ 1, same as X1)	
		Thousand's digit	X9 valid mode (0 ~ 1, same as X1)	
		Ten thousand's digit	X10 valid mode (0 ~ 1, same as X1)	

These Parameters are used to set the valid mode of X terminals.

0: High level valid

The X terminal is valid when being connected with COM, and invalid when being disconnected from COM.

1: Low level valid

The X terminal is invalid when being connected with COM, and valid when being disconnected

from COM.

7.6 Group F5: Output Terminals

The SINUS VEGA provides an analog output (AO) terminal, a digital output (DO) terminal, a relay terminal and a DO terminal (used for high-speed pulse output or open-collector switch signal output) as standard. If these output terminals cannot satisfy requirements, use an optional I/O extension card that provides an AO terminal (AO2), a relay terminal (relay 2) and a DO terminal (DO).

F5-00	DO terminal output mode		Default	0
	Setting Range	0	Pulse output (DO)	
		1	Switch signal output (DO)	

The DO terminal is programmable multiplexing terminal. It can be used for high-speed pulse output (Pulse), with maximum frequency of 100 kHz. Refer to F5-06 for relevant functions of DO(Pulse). It can also be used as open collector switch signal output (Switch).

F5-01	DO (Switch) function (open-collector output terminal)	Default	0
F5-02	Relay function (T/A-T/B-T/C)	Default	2
F5-03	Extension card relay function (P/A-P/B-P/C)	Default	0
F5-04	Y1 function selection (open-collector output terminal)	Default	1
F5-05	Extension card DO function	Default	4

These five Parameters are used to select the functions of the five digital output terminals. T/A-T/B-T/C and P/A-P/B-P/C are respectively the relays on the control board and the extension card.

The functions of the output terminals are described in the following table.

Value	Function	Description
0	No output	The terminal has no function.
1	AC drive running	When the AC drive is running and has output frequency (can be zero), the terminal becomes ON.
2	Fault output (stop)	When the AC drive stops due to a fault, the terminal becomes ON.
3	Frequency-level detection FDT1 output	Refer to the descriptions of F8-19 and F8-20.
4	Frequency reached	Refer to the descriptions of F8-21.

Value	Function	Description
5	Zero-speed running (no output at stop)	If the AC drive runs with the output frequency of 0, the terminal becomes ON. If the AC drive is in the stop state, the terminal becomes OFF.
6	Motor overload pre-warning	The AC drive judges whether the motor load exceeds the overload pre-warning threshold before performing the protection action. If the pre-warning threshold is exceeded, the terminal becomes ON. For motor overload Parameters, see the descriptions of F9-00 to F9-02.
7	AC drive overload pre-warning	The terminal becomes ON 10s before the AC drive overload protection action is performed.
8	Set count value reached	The terminal becomes ON when the count value reaches the value set in FB-08.
9	Designated count value reached	The terminal becomes ON when the count value reaches the value set in FB-09.
10	Length reached	The terminal becomes ON when the detected actual length exceeds the value set in FB-05
11	PLC cycle complete	When simple PLC completes one cycle, the terminal outputs a pulse signal with width of 250 ms.
12	Accumulative running time reached	If the accumulative running time of the AC drive exceeds the time set in F8-17, the terminal becomes ON.
13	Frequency limited	If the set frequency exceeds the frequency upper limit or lower limit and the output frequency of the AC drive reaches the upper limit or lower limit, the terminal becomes ON.
14	Torque limited	In speed control mode, if the output torque reaches the torque limit, the AC drive enters the stall protection state and meanwhile the terminal becomes ON.
15	Ready for RUN	If the AC drive main circuit and control circuit become stable, and the AC drive detects no fault and is ready for RUN, the terminal becomes ON.
16	AI1>AI2	When the input of AI1 is larger than the input of AI2, the terminal becomes ON.
17	Frequency upper limit Reached	If the running frequency reaches the upper limit, the terminal becomes ON.
18	Frequency lower limit reached (no output at stop)	If the running frequency reaches the lower limit, the terminal becomes ON. In the stop state, the terminal becomes OFF.
19	Undervoltage state output	If the AC drive is in undervoltage state, the terminal becomes ON.
20	Communication setting	Refer to the communication protocol.

Value	Function	Description
21	Reserved	Reserved.
22	Reserved	Reserved.
23	Zero-speed running 2 (having output at stop)	If the output frequency of the AC drive is 0, the terminal becomes ON. In the state of stop, the signal is still ON.
24	Accumulative power-on time reached	If the AC drive accumulative power-on time (F7-13) exceeds the value set in F8-16, the terminal becomes ON.
25	Frequency level detection FDT2 output	Refer to the descriptions of F8-28 and F8-29.
26	Frequency 1 reached	Refer to the descriptions of F8-30 and F8-31.
27	Frequency 2 reached	Refer to the descriptions of F8-32 and F8-33.
28	Current 1 reached	Refer to the descriptions of F8-38 and F8-39.
29	Current 2 reached	Refer to the descriptions of F8-40 and F8-41.
30	Timing reached	If the timing function (F8-42) is valid, the terminal becomes ON after the current running time of the AC drive reaches the set time.
31	A11 input limit exceeded	If A11 input is larger than the value of F8-46 (A11 input voltage upper limit) or lower than the value of F8-45 (A11 input voltage lower limit), the terminal becomes ON.
32	Load becoming 0	If the load becomes 0, the terminal becomes ON.
33	Reverse running	If the AC drive is in the reverse running state, the terminal becomes ON.
34	Zero current state	Refer to the descriptions of F8-28 and F8-29.
35	Module temperature reached	If the heatsink temperature of the inverter module (F7-07) reaches the set module temperature threshold (F8-47), the terminal becomes ON.
36	Software current limit exceeded	Refer to the descriptions of F8-36 and F8-37.
37	Frequency lower limit reached (having output at stop)	If the running frequency reaches the lower limit, the terminal becomes ON. In the stop state, the signal is still ON.
38	Alarm output	If a fault occurs on the AC drive and the AC drive continues to run, the terminal outputs the alarm signal.
39	Motor overheat warning	If the motor temperature reaches the temperature set in F9-58 (Motor overheat warning threshold), the terminal becomes ON. You can view the motor temperature by using U0-34.

Value	Function	Description
40	Current running time reached	If the current running time of AC drive exceeds the value of F8-53, the terminal becomes ON

F5-06	DO function selection (Pulse output terminal)	Default	0
F5-07	AO1 function selection	Default	0
F5-08	AO2 function selection	Default	1

The output pulse frequency of the DO(Pulse) terminal ranges from 0.01 kHz to "Maximum DO(Pulse) output frequency" (F5-09).

The value of F5-09 is between 0.01 kHz and 100.00 kHz.

The output range of AO1 and AO2 is 0–10 V or 0–20 mA.

The relationship between pulse and analog output ranges and corresponding functions is listed in the following table.

Value	Function	Range (Corresponding to Pulse or Analog Output Range 0.0%–100.0%)	
0	Running frequency	0 to maximum output frequency	
1	Set frequency	0 to maximum output frequency	
2	Output current	0 to 2 times of rated motor current	
3	Output torque (absolute value)	0 to 2 times of rated motor torque	
4	Output power	0 to 2 times of rated power	
5	Output voltage	0 to 1.2 times of rated AC drive voltage	
6	Pulse input	0.01kHz ~ 100.00kHz	
7	AI1	0V ~ +10V	
8	AI2	0V ~ +10V (Or 0 ~ 20mA)	
9	AI3	0V ~ +10V	
10	Length	0 ~ maximum set length	
11	Count value	0 ~ maximum count value	
12	Communication setting	0.0% ~ 100.0%	
13	Motor rotational speed	0 ~ rotational speed corresponding to maximum output frequency	
14	Output current	0.0A ~ 1000.0A	
15	Output voltage	0.0V ~ 1000.0V	
F5-09	Maximum DO output frequency	Default	50.00kHz
	Setting Range	0.01kHz ~ 100.00kHz	

If the DO terminal is used for pulse output, this Parameter is used to set the maximum frequency of

pulse output.

F5-10	AO1 offset coefficient	Default	0.0%
	Setting Range	-100.0% ~ +100.0%	
F5-11	AO1 gain	Default	1.00
	Setting Range	-10.00 ~ +10.00	
F5-12	AO2 offset coefficient	Default	0.00%
	Setting Range	-100.0% ~ +100.0%	
F5-13	AO2 gain	Default	1.00
	Setting Range	-10.00 ~ +10.00	

These Parameters are used to correct the zero drift of analog output and the output amplitude deviation. They can also be used to define the desired AO curve.

If "b" represents zero offset, "k" represents gain, "Y" represents actual output, and "X" represents standard output, the actual output is: $Y = kX + b$.

The zero offset coefficient 100% of AO1 and AO2 corresponds to 10 V (or 20 mA). The standard output refers to the value corresponding to the analog output of 0 to 10 V (or 0 to 20 mA) with no zero offset or gain adjustment.

For example, if the analog output is used as the running frequency, and it is expected that the output is 8 V when the frequency is 0 and 3 V at the maximum frequency, the gain shall be set to -0.50, and the zero offset shall be set to 80%.

F5-17	DO output delay time	Default	0.0s
	Setting Range	0.0s ~ 3600.0s	
F5-18	RELAY1 output delay time	Default	0.0s
	Setting Range	0.0s ~ 3600.0s	
F5-19	RELAY2 output delay time	Default	0.0s
	Setting Range	0.0s ~ 3600.0s	
F5-20	Y1 output delay time	Default	0.0s
	Setting Range	0.0s ~ 3600.0s	
F5-21	Reserved	Default	-
	Setting Range	-	

These Parameters are used to set the delay time of output terminals DO(switch), relay 1, relay 2 and Y1 from status change to actual output.

F5-22	DO valid mode selection		Default	00000
	Setting Range	Unit's digit	DO(software) valid mode	
		0	Positive logic	
		1	Negative logic	
		Ten's digit	RELAY1 valid mode(0 ~ 1, same as DO(software))	
		Hundred's digit	RELAY2 valid mode(0 ~ 1, same as DO(software))	
		Thousand's digit	Y1 valid mode(0 ~ 1, same as DO(software))	
		Ten thousand's digit	DO valid mode(0 ~ 1, same as DO(software)R)	

It is used to set the logic of output terminals DO(software), relay 1, relay 2 and Y1.

0: Positive logic

The output terminal is valid when being connected with COM, and invalid when being disconnected from COM.

1: Negative logic

The output terminal is invalid when being connected with COM, and valid when being disconnected from COM

7.7 Group F6 Start/Stop Control

F6-00	Start mode		Default	0
	Setting Range	0	Direct start	
		1	Rotational speed tracking restart	
		2	Pre-excited start (asynchronous motor)	

0: Direct start

– If the DC braking time is set to 0, the AC drive starts to run at the startup frequency.

– If the DC braking time is not 0, the AC drive performs DC braking first and then starts to run at the startup frequency. It is applicable to small-inertia load application where the motor is likely to rotate at startup.

1: Rotational speed tracking restart

The AC drive judges the rotational speed and direction of the motor first and then starts at the tracked frequency. Such smooth start has no impact on the rotating motor. It is applicable to the restart upon instantaneous power failure of large-inertia load. To ensure the performance of rotational speed tracking restart, set the motor Parameters in group F1 correctly.

2: Pre-excited start (asynchronous motor)

It is valid only for asynchronous motor and used for building the magnetic field before the motor

runs. For pre-excited current and pre-excited time, see Parameters of F6-05 and F6-06.

– If the pre-excited time is 0, the AC drive cancels pre-excitation and starts to run at startup frequency.

– If the pre-excited time is not 0, the AC drive pre-excites first before startup, improving the dynamic response of the motor.

F6-01	Rotational speed tracking mode		Default	0
	Setting Range	0	From frequency at stop	
		1	From zero speed	
		2	From maximum frequency	

To complete the rotational speed tracking process within the shortest time, select the proper mode in which the AC drive tracks the motor rotational speed.

0: From frequency at stop

It is the commonly selected mode.

1: From zero frequency

It is applicable to restart after a long time of power failure.

2: From the maximum frequency, it is applicable to the power-generating load.

F6-02	Rotational speed tracking speed	Default	20
	Setting Range		1 ~ 100

In the rotational speed tracking restart mode, select the rotational speed tracking speed. The larger the value is, the faster the tracking is. However, too large value may cause unreliable tracking.

F6-03	Startup frequency	Default	0.00Hz
	Setting Range		0.00Hz ~ 10.00Hz
F6-04	Startup frequency holding time	Default	0.0s
	Setting Range		0.0s ~ 100.0s

To ensure the motor torque at AC drive startup, set a proper startup frequency. In addition, to build excitation when the motor starts up, the startup frequency must be held for a certain period.

The startup frequency (F6-03) is not restricted by the frequency lower limit. If the set target frequency is lower than the startup frequency, the AC drive will not start and stays in the standby

state.

During switchover between forward rotation and reverse rotation, the startup frequency holding time is disabled. The holding time is not included in the acceleration time but in the running time of simple PLC.

Example 1:

F0-03 = 0 The frequency source is digital setting.

F0-08 = 2.00Hz The digital setting frequency is 2.00 Hz.

F6-03 = 5.00Hz The startup frequency is 5.00 Hz.

F6-04 = 2.0s The startup frequency holding time is 2.0s.

In this example, the AC drive stays in the standby state and the output frequency is 0.00 Hz.

Example 2:

F0-03 = 0 The frequency source is digital setting.

F0-08 = 10.00Hz The digital setting frequency is 10.00 Hz.

F6-03 = 5.00Hz The startup frequency is 5.00 Hz.

F6-04 = 2.0s The startup frequency holding time is 2.0s.

In this example, the AC drive accelerates to 5.00 Hz, and then accelerates to the set frequency 10.00 Hz after 2s.

Startup DC braking is generally used during restart of the AC drive after the rotating motor stops. Pre-excitation is used to make the AC drive build magnetic field for the asynchronous motor before startup to improve the responsiveness.

Startup DC braking is valid only for direct start (F6-00 = 0). In this case, the AC drive performs DC braking at the set startup DC braking current. After the startup DC braking time, the AC drive starts to run. If the startup DC braking time is 0, the AC drive starts directly without DC braking. The larger the startup DC braking current is, the larger the braking force is.

If the startup mode is pre-excited start (F6-00 = 3), the AC drive builds magnetic field based on

the set pre-excited current. After the pre-excited time, the AC drive starts to run. If the pre-excited time is 0, the AC drive starts directly without pre-excitation.

The startup DC braking current or pre-excited current is a percentage relative to the base value.

F6-07	Acceleration/Deceleration mode		Default	0
	Setting Range	0	Linear acceleration/deceleration	
		1	S-curve acceleration/deceleration A	
		2	S-curve acceleration/deceleration B	

It is used to set the frequency change mode during the AC drive start and stop process.

0: Linear acceleration/deceleration

The output frequency increases or decreases in linear mode. The SINUS VEGA provides four group of acceleration/deceleration time, which can be selected by using F4-00 to F4-08.

1: S-curve acceleration/deceleration A

The output frequency increases or decreases along the S curve. This mode is generally used in the applications where start and stop processes are relatively smooth, such as elevator and conveyor belt. F6-08 and F6-09 respectively define the time proportions of the start segment and the end segment.

2: S-curve acceleration/deceleration B

In this curve, the rated motor frequency f_b is always the inflexion point. This mode is usually used in applications where acceleration/deceleration is required at the speed higher than the rated frequency.

When the set frequency is higher than the rated frequency, the acceleration/deceleration time is:

$$t = \left(\frac{4}{9} \times \left(\frac{f}{f_b} \right)^2 + \frac{5}{9} \right) \times T$$

In the formula, f is the set frequency, f_b is the rated motor frequency and T is the acceleration time from 0 Hz to f_b .

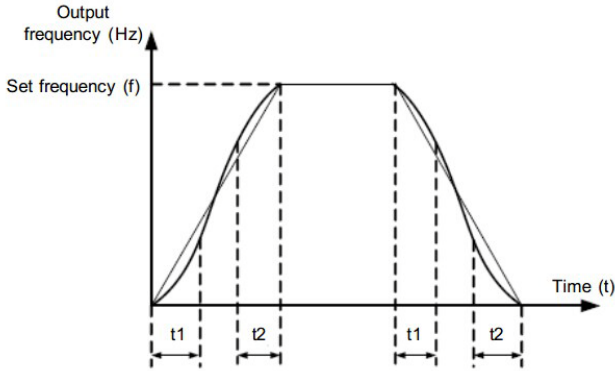

Figure 6-11 S-curve acceleration/deceleration A

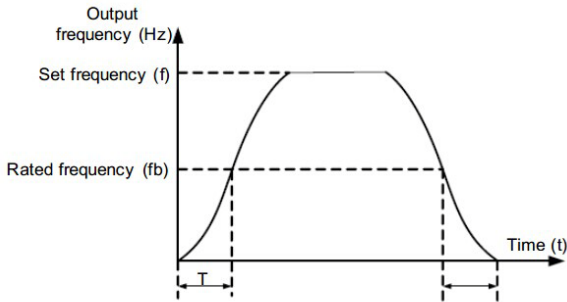

Figure 6-13 S-curve acceleration/deceleration B

F6-08	Time proportion of S-curve start segment	Default	30.0%
	Setting Range	0.0% ~ (100.0%-F6-09)	
F6-09	Time proportion of S-curve end segment	Default	30.0%
	Setting Range	0.0% ~ (100.0%-F6-08)	

These two Parameters respectively define the time proportions of the start segment and the end segment of S-curve acceleration/deceleration. They must satisfy the requirement: $F6-08 + F6-09 \leq 100.0\%$.

In Figure 6-11, t_1 is the time defined in F6-08, within which the slope of the output frequency change increases gradually. t_2 is the time defined in F6-09, within which the slope of the output

frequency change gradually decreases to 0. Within the time between t1 and t2, the slope of the output frequency change remains unchanged, that is, linear acceleration/deceleration.

F6-10	Stop mode	Default	0
	Setting Range	0	Decelerate to stop
		1	Coast to stop

0: Decelerate to stop

After the stop command is enabled, the AC drive decreases the output frequency according to the deceleration time and stops when the frequency decreases to zero.

1: Coast to stop

After the stop command is enabled, the AC drive immediately stops the output. The motor will coast to stop based on the mechanical inertia

F6-11	Initial frequency of stop DC braking	Default	0.00Hz
	Setting Range	0.00Hz ~ maximum frequency	
F6-12	Waiting time of stop DC braking	Default	0.0s
	Setting Range	0.0s ~ 36.0s	
F6-13	Stop DC braking current	Default	0%
	Setting Range	0% ~ 100%	
F6-14	Stop DC braking time	Default	0.0s
	Setting Range	0.0s ~ 36.0s	

F6-11 (Initial frequency of stop DC braking)

During the process of decelerating to stop, the AC drive starts DC braking when the running frequency is lower than the value set in F6-11.

F6-12 (Waiting time of stop DC braking)

When the running frequency decreases to the initial frequency of stop DC braking, the AC drive stops output for a certain period and then starts DC braking. This prevents faults such as overcurrent caused due to DC braking at high speed.

F6-13 (Stop DC braking current)

This Parameter specifies the output current at DC braking and is a percentage relative to the base value.

– If the rated motor current is less than or equal to 80% of the rated AC drive current, the base value is the rated motor current.

– If the rated motor current is greater than 80% of the rated AC drive current, the base value is 80% of the rated AC drive current.

F6-14 (Stop DC braking time)

This Parameter specifies the holding time of DC braking. If it is set to 0, DC braking is cancelled.

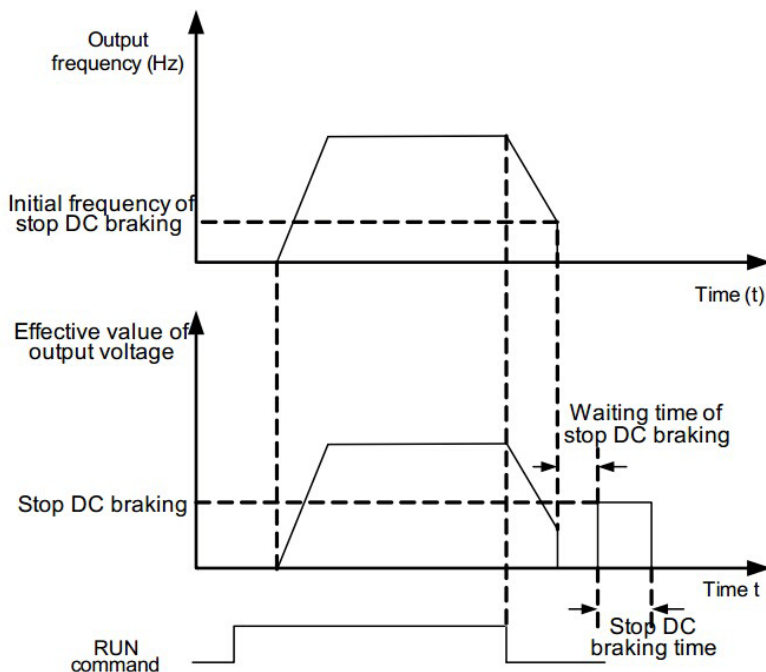

Figure 6-13 Stop DC braking process

F6-15	Brake use ratio	Default	100%
	Setting Range	0% ~ 100%	

It is valid only for the AC drive with internal braking unit and used to adjust the duty ratio of the braking unit. The larger the value of this Parameter is, the better the braking result will be. However, too larger value causes great fluctuation of the AC drive bus voltage during the braking process.

7.8 Group F7 Operation Panel and Display

F7-01	MF Key function selection		Default	0
	Setting Range	0	MF key disabled	
		1	Switchover between operation Panel control and remote command control (terminal or communication)	
		2	Switchover between forward rotation and reverse rotation	
		3	Forward JOG	
		4	Reverse JOG	

MF key refers to multifunctional key. You can set the function of the MF key by using this Parameter. You can perform switchover by using this key both in stop or running state.

0: MF key disabled

1: Switchover between operation Panel control and remote command control (terminal or communication).

You can perform switchover from the current command source to the operation Panel control (local operation). If the current command source is operation Panel control, this key is invalid.

2: Switchover between forward rotation and reverse rotation

You can change the direction of the frequency reference by using the MF key. It is valid only when the current command source is operation Panel control.

3: Forward JOG

You can perform forward JOG (FJOG) by using the MF key.

4: Reverse JOG

You can perform reverse JOG (FJOG) by using the MF key.

F7-02	STOP/RESET key function		Default	1
	Setting Range	0	STOP/RESET key enabled only in operation Panel control	
		1	STOP/RESET key enabled in any operation mode	
F7-03	LED display running Parameters 1		Default	1F

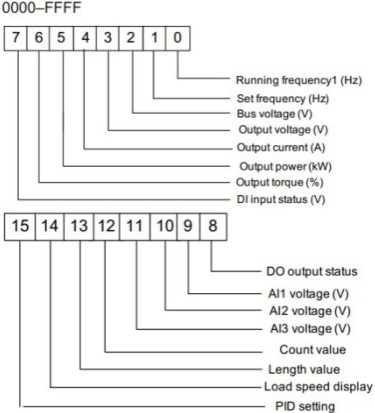
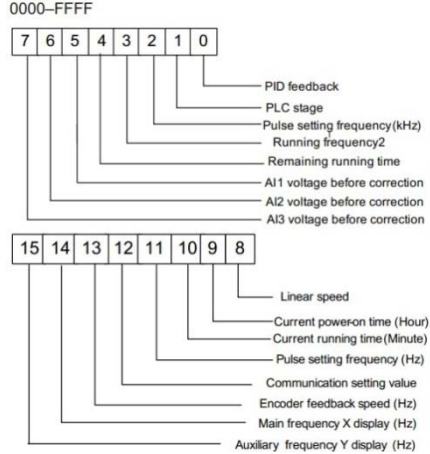
	Setting Range	0000~ FFFF	 <p>If a Parameter needs to be displayed during the running, set the corresponding bit to 1, and set F7-03 to the hexadecimal equivalent of this binary number.</p>
F7-04	Setting Range	0000~ FFFF	<p>LED display running Parameters 2</p> <p>Default 0</p>  <p>If a Parameter needs to be displayed during the running, set the corresponding bit to 1, and set F7-03 to the hexadecimal equivalent of this binary number.</p>

These two Parameters are used to set the Parameters that can be viewed when the AC drive is in the running state. You can view a maximum of 32 running state Parameters that are displayed from the lowest bit of F7-03.

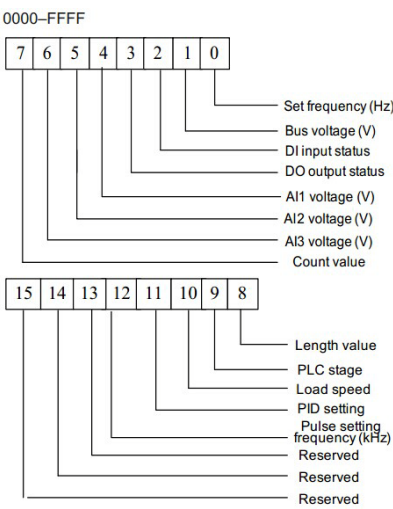
LED display stop Parameters		Default	0
F7-05	Setting Range 0000~ FFFF	 <p>If a Parameter needs to be displayed during the running, set the corresponding bit to 1, and set F7-05 to the hexadecimal equivalent of this binary number.</p>	

F7-06	Load speed display coefficient	Default	1.0000
	Setting Range	0.0001 ~ 6.5000	

This Parameter is used to adjust the relationship between the output frequency of the AC drive and the load speed. For details, see the description of F7-12.

F7-07	Heatsink temperature of inverter Module	Default	—
	Setting Range	0.0°C ~ 100.0°C	

It is used to display the insulated gate bipolar transistor (IGBT) temperature of the inverter module, and the IGBT overheat protection value of the inverter module depends on the model.

F7-08	Temporary software version	Default	—
	Setting Range	—	

It is used to display the temporary software version of the control board.

F7-09	Accumulative running time	Default	0 hour
	Setting Range	0h ~ 65535h	

It is used to display the accumulative running time of the AC drive. After the accumulative running time reaches the value set in F8-17, the terminal with the digital output function 12 becomes ON.

F7-10	Product number	Default	
	Setting Range	AC drive product number	
F7-11	Software version	Default	
	Setting Range	Software version of control board	
F7-12	Number of decimal places for load speed display	Default	1
	Setting Range	0	0 decimal place
		1	1 decimal place
		2	2 decimal places
		3	3 decimal places

F7-12 is used to set the number of decimal places for load speed display. The following gives an example to explain how to calculate the load speed:

Assume that F7-06 (Load speed display coefficient) is 2.000 and F7-12 is 2 (2 decimal places). When the running frequency of the AC drive is 40.00 Hz, the load speed is $40.00 \times 2.000 = 80.00$ (display of 2 decimal places).

If the AC drive is in the stop state, the load speed is the speed corresponding to the set frequency, namely, "set load speed". If the set frequency is 50.00 Hz, the load speed in the stop state is $50.00 \times 2.000 = 100.00$ (display of 2 decimal places).

F7-13	Accumulative power-on time	Default	—
	Setting Range	0 ~ 65535 hour	

It is used to display the accumulative power-on time of the AC drive since the delivery. If the time reaches the set power-on time (F8-17), the terminal with the digital output function 24 becomes ON.

F7-14	Accumulative power consumption	Default	-
	Setting Range	0 ~ 65535 kWh	

It is used to display the accumulative power consumption of the AC drive until now.

7.9 Group F8 Auxiliary Functions

F8-00	JOG running frequency	Default	2.00Hz
	Setting Range	0.00Hz ~ maximum frequency	
F8-01	JOG acceleration time	Default	20.0s
	Setting Range	0.0s ~ 6500.0s	
F8-02	JOG deceleration time	Default	20.0s
	Setting Range	0.0s ~ 6500.0s	

These Parameters are used to define the set frequency and acceleration/deceleration time of the AC drive when jogging. The startup mode is "Direct start" (F6-00 = 0) and the stop mode is "Decelerate to stop" (F6-10 = 0) during jogging.

F8-03	Acceleration time 2	Default	Model dependent
	Setting Range	0.0s ~ 6500.0s	
F8-04	Deceleration time 2	Default	Model dependent
	Setting Range	0.0s ~ 6500.0s	
F8-05	Acceleration time 3	Default	Model dependent
	Setting Range	0.0s ~ 6500.0s	
F8-06	Deceleration time 3	Default	Model dependent
	Setting Range	0.0s ~ 6500.0s	
F8-07	Acceleration time 4	Default	Model dependent
	Setting Range	0.0s ~ 6500.0s	
F8-08	Deceleration time 4	Default	Model dependent
	Setting Range	0.0s ~ 500.0s	

The SINUS VEGA provides a total of four groups of acceleration/deceleration time, that is, the preceding three groups and the group defined by F0-17 and F0-18. Definitions of four groups are completely the same. You can switch over between the four groups of acceleration/deceleration time through different state combinations of X terminals. For more details, see the descriptions of F4-01 to F4-05.

F8-09	Jump frequency 1	Default	0.00Hz
	Setting Range	0.00Hz ~ maximum frequency	
F8-10	Jump frequency 2	Default	0.00Hz
	Setting Range	0.00 Hz ~ maximum frequency	
F8-11	Frequency jump amplitude	Default	0.00Hz
	Setting Range	0.00 ~ maximum frequency	

If the set frequency is within the frequency jump range, the actual running frequency is the jump frequency close to the set frequency. Setting the jump frequency helps to avoid the mechanical

resonance point of the load.

The SINUS VEGA supports two jump frequencies. If both are set to 0, the frequency jump function is disabled. The principle of the jump frequencies and jump amplitude is shown in the following figure.

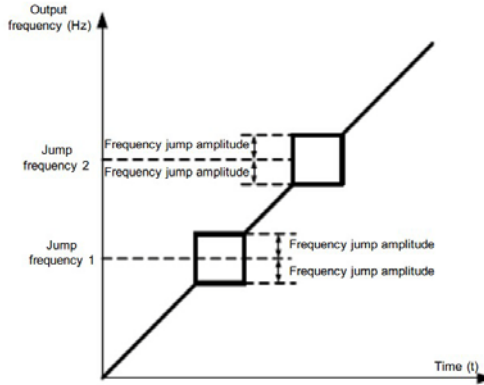

Figure 6-14 Principle of the jump frequencies and jump amplitude

F8-12	Forward/Reverse rotation dead-zone time	Default	0.0s
	Setting Range	0.0s ~ 3000.0s	

It is used to set the time when the output is 0 Hz at transition of the AC drive forward rotation and reverse rotation, as shown in the following figure.

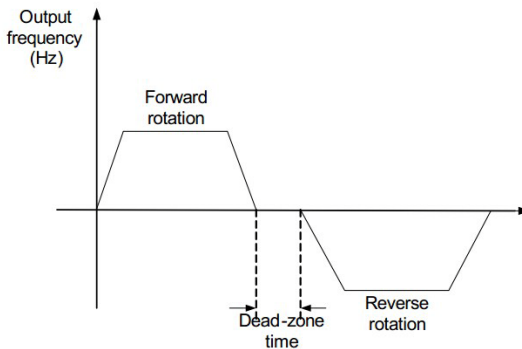

Figure 6-15 Forward/Reverse rotation dead-zone time

F8-13	Reverse control	Default	0
	Setting Range	0	Enabled
		1	Disabled

It is used to set whether the AC drive allows reverse rotation. In the applications where reverse rotation is prohibited, set this Parameter to 1.

F8-14	Running mode when set frequency lower than frequency lower limit	Default	0
	Setting Range	0	Run at frequency lower limit
		1	Stop
		2	Run at zero speed

It is used to set the AC drive running mode when the set frequency is lower than the frequency lower limit. The SINUS VEGA provides three running modes to satisfy requirements of various applications.

F8-15	Droop control	Default	0.00Hz
	Setting Range	0.00Hz ~ 10.00Hz	

This function is used for balancing the workload allocation when multiple motors are used to drive the same load. The output frequency of the AC drives decreases as the load increases. You can reduce the workload of the motor under load by decreasing the output frequency for this motor, implementing workload balancing between multiple motors.

F8-16	Accumulative power-on time threshold	Default	0h
	Setting Range	0h ~ 65000h	

If the accumulative power-on time (F7-13) reaches the value set in this Parameter, the corresponding DO terminal becomes ON.

For example, combining virtual X/DO functions, to implement the function that the AC drive reports an alarm when the actual accumulative power-on time reaches the threshold of 100 hours, perform the setting as follows:

- 1) Set virtual X1 to user-defined fault 1: A1-00 = 44.
- 2) Set that the valid state of virtual X1 is from virtual Y1: A1-05 = 0000.
- 3) Set virtual Y1 to power-on time reached: A1-11 = 24.
- 4) Set the accumulative power-on time threshold to 100 h: F8-16 = 100 h.

Then, the AC drive reports Err27 when the accumulative power-on time reaches 100 hours.

F8-17	Accumulative running time threshold	Default	0h
	Setting Range	0h ~ 65000h	

It is used to set the accumulative running time threshold of the AC drive. If the accumulative running time (F7-09) reaches the value set in this Parameter, the corresponding DO terminal becomes ON.

F8-18	Startup protection	Default	0
	Setting Range	0	No
		1	Yes

This Parameter is used to set whether to enable the safety protection. If it is set to 1, the AC drive does not respond to the run command valid upon AC drive power-on (for example, an input terminal is ON before power-on). The AC drive responds only after the run command is cancelled and becomes valid again.

In addition, the AC drive does not respond to the run command valid upon fault reset of the AC drive. The run protection can be disabled only after the run command is cancelled.

In this way, the motor can be protected from responding to run commands upon power-on or fault reset in unexpected conditions.

F8-19	Frequency detection value(FDT1)	Default	50.00Hz
	Setting Range	0.00Hz ~ maximum frequency	
F8-20	Frequency detection hysteresis (FDT hysteresis 1)	Default	5.0%
	Setting Range	0.0% ~ 100.0% (FDT1 level)	

If the running frequency is higher than the value of F8-19, the corresponding DO terminal becomes ON. If the running frequency is lower than value of F8-19, the DO terminal goes OFF. These two Parameters are respectively used to set the detection value of output frequency and hysteresis value upon cancellation of the output. The value of F8-20 is a percentage of the hysteresis frequency to the frequency detection value (F8-19).

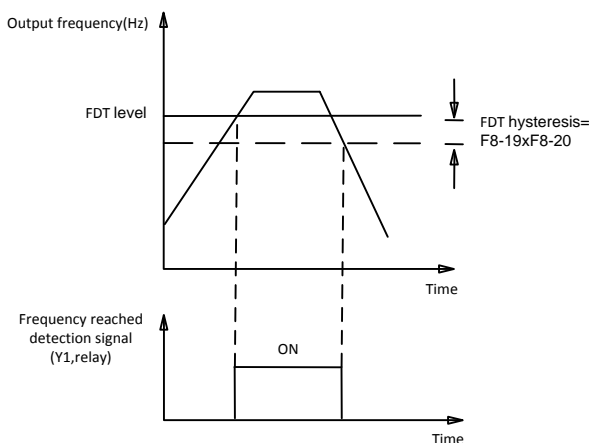

Figure 6-16 FDT level

F8-21	Detection range of frequency reached	Default	0.0%
	Setting Range	0.00 ~ 100%(maximum frequency)	

If the AC drive running frequency is within the certain range of the set frequency, the corresponding DO terminal becomes ON.

This Parameter is used to set the range within which the output frequency is detected to reach the set frequency. The value of this Parameter is a percentage relative to the maximum frequency. The detection range of frequency reached is shown in the following figure.

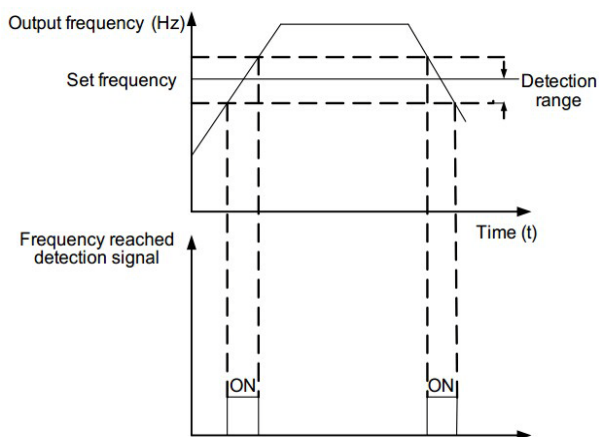

Figure 6-17 Detection range of frequency reached

F8-22	Jump frequency during acceleration/deceleration	Default	0
	Setting Range	0: Disabled; 1: Enabled	

It is used to set whether the jump frequencies are valid during acceleration/deceleration.

When the jump frequencies are valid during acceleration/deceleration, and the running frequency is within the frequency jump range, the actual running frequency will jump over the set frequency jump amplitude (rise directly from the lowest jump frequency to the highest jump frequency). The following figure shows the diagram when the jump frequencies are valid during acceleration/deceleration.

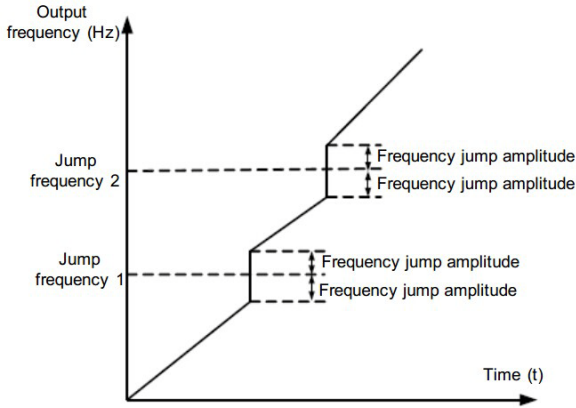

Figure 6-18 Diagram when the jump frequencies are valid during acceleration/deceleration

F8-25	Frequency switchover point between acceleration time 1 and acceleration time 2	Default	0.00Hz
	Setting Range	0.00Hz ~ maximum frequency	
F8-26	Frequency switchover point between deceleration time 1 and deceleration time 2	Default	0.00Hz
	Setting Range	0.00Hz ~ maximum frequency	

This function is valid when motor 1 is selected and acceleration/deceleration time switchover is not performed by means of X terminal. It is used to select different groups of acceleration/deceleration time based on the running frequency range rather than X terminal during the running process of the AC drive.

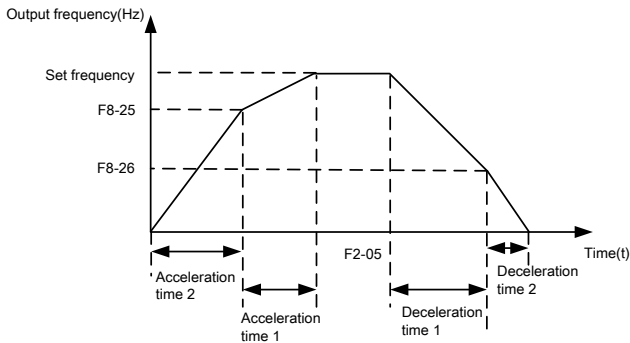

Figure 6-19 Acceleration/deceleration time switchovers

During acceleration, if the running frequency is smaller than the value of F8-25, acceleration time 2 is selected. If the running frequency is larger than the value of F8-25, acceleration time 1 is selected.

During deceleration, if the running frequency is larger than the value of F8-26, deceleration time 1 is selected. If the running frequency is smaller than the value of F8-26, deceleration time 2 is selected.

F8-27	Terminal JOG preferred	Default	0
	Setting Range	0: Disabled; 1: Enabled	

It is used to set whether terminal JOG is preferred.

If terminal JOG is preferred, the AC drive switches to terminal JOG running state when there is a terminal JOG command during the running process of the AC drive.

F8-28	Frequency detection value (FDT2)	Default	50.00Hz
	Setting Range	0.00Hz ~ maximum frequency	
F8-29	Frequency detection hysteresis (FDT hysteresis 2)	Default	5.0%
	Setting Range	0.0% ~ 100.0 % (FDT2 level)	

The frequency detection function is the same as FDT1 function. For details, refer to the descriptions of F8-19 and F8-20.

F8-30	Any frequency reaching detection value 1	Default	50.00Hz
	Setting Range	0.00Hz ~ maximum frequency	
F8-31	Any frequency reaching detection amplitude 1	Default	0.0%
	Setting Range	0.0% ~ 100.0%(maximum frequency)	
F8-32	Any frequency reaching detection value 2	Default	50.00Hz
	Setting Range	0.00Hz ~ maximum frequency	
F8-33	Any frequency reaching detection amplitude 2	Default	0.0%
	Setting Range	0.0% ~ 100.0%(maximum Frequency)	

If the output frequency of the AC drive is within the positive and negative amplitudes of the any frequency reaching detection value, the corresponding DO becomes ON.

The SINUS VEGA provides two groups of any frequency reaching detection Parameters, including frequency detection value and detection amplitude, as shown in the following figure.

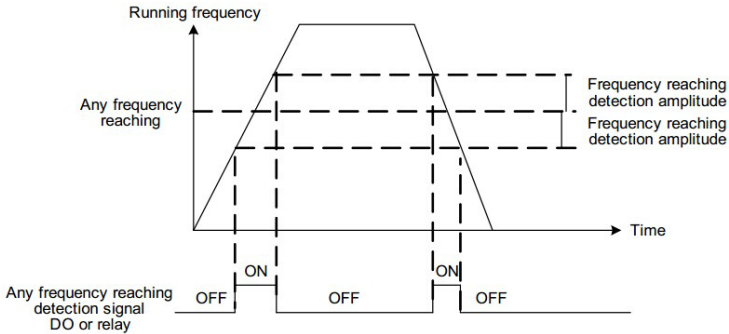

Figure 6-20 Any frequency reaching detection

F8-34	Zero current detection level	Default	5.0%
	Setting Range	0.0% ~ 300.0% (rated motor current)	
F8-35	Zero current detection delay time	Default	0.10s
	Setting Range	0.00s ~ 600.00s	

If the output current of the AC drive is equal to or less than the zero current detection level and the duration exceeds the zero current detection delay time, the corresponding DO becomes ON. The zero current detection is shown in the following figure.

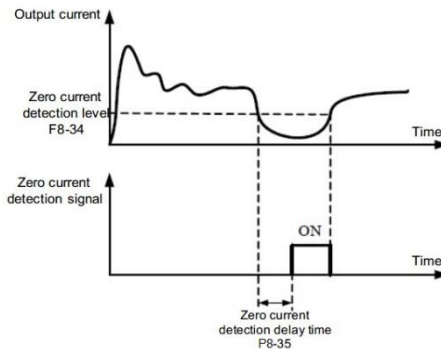

Figure 6-21 Zero current detection

F8-36	Output overcurrent threshold	Default	200.0%
	Setting Range	0.0% (no detection); 0.1% ~ 300.0% (rated motor current)	
F8-37	Output overcurrent detection delay time	Default	0.00s
	Setting Range	0.00s ~ 600.00s	

If the output current of the AC drive is equal to or higher than the overcurrent threshold and the

duration exceeds the detection delay time, the corresponding DO becomes ON. The output overcurrent detection function is shown in the following figure.

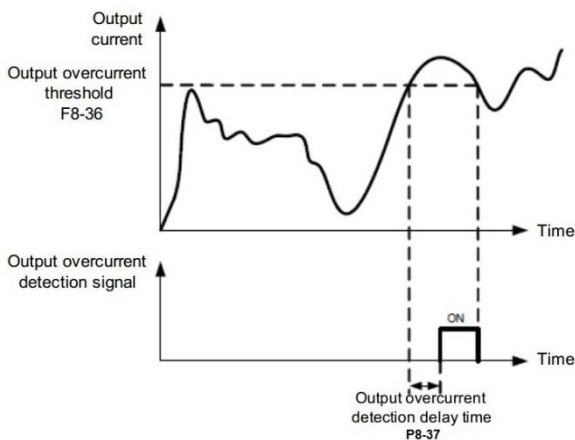

Figure 6-22 Output overcurrent detection

F8-38	Any current reaching 1	Default	100.0%
	Setting Range	0.0% ~ 300.0%(rated motor current)	
F8-39	Any current reaching 1 amplitude	Default	0.0%
	Setting Range	0.0% ~ 300.0%(rated motor current)	
F8-40	Any current reaching 2	Default	100.0%
	Setting Range	0.0% ~ 300.0%(rated motor current)	
F8-41	Any current reaching 2 amplitude	Default	0.0%
	Setting Range	0.0% ~ 300.0%(rated motor current)	

If the output current of the AC drive is within the positive and negative amplitudes of any current reaching detection value, the corresponding DO becomes ON.

The SINUS VEGA provides two groups of any current reaching detection Parameters, including current detection value and detection amplitudes, as shown in the following figure.

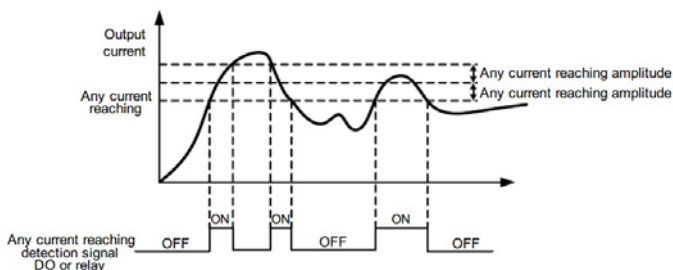

Figure 6-23 Any current reaching detection

F8-42	Timing function	Default	0
	Setting Range	0	Disabled
1		Enabled	
F8-43	Timing duration source	Default	0
	Setting Range	0	F8-44
		1	AI1
		2	AI2
		3	AI3
(100% of analog input corresponds to the value of F8-44)			
F8-44	Timing duration	Default	0.0Min
	Setting Range	0.0Min ~ 6500.0Min	

These Parameters are used to implement the AC drive timing function.

If F8-42 is set to 1, the AC drive starts to time at startup. When the set timing duration is reached, the AC drive stops automatically and meanwhile the corresponding DO becomes ON.

The AC drive starts timing from 0 each time it starts up and the remaining timing duration can be queried by U0-20.

The timing duration is set in F8-43 and F8-44, in unit of minute.

F8-45	AI1 input voltage lower limit	Default	3.10V
	Setting Range	0.00V ~ F8-46	
F8-46	AI1 input voltage upper limit	Default	6.80V
	Setting Range	F8-45 ~ 10.00V	

These two Parameters are used to set the limits of the input voltage to provide protection on the AC drive. When the AI1 input is larger than the value of F8-46 or smaller than the value of F8-

45, the corresponding DO becomes ON, indicating that AI1 input exceeds the limit.

F8-47	Module temperature threshold	Default	75°C
	Setting Range	0.00V ~ F8-46	

When the heatsink temperature of the AC drive reaches the value of this Parameter, the corresponding DO becomes ON, indicating that the module temperature reaches the threshold.

F8-48	Cooling fan control	Default	0
	Setting Range	0: Fan working during running; 1: Fan working continuously	

It is used to set the working mode of the cooling fan. If this Parameter is set to 0, the fan works when the AC drive is in running state. When the AC drive stops, the cooling fan works if the heatsink temperature is higher than 40°C, and stops working if the heatsink temperature is lower than 40°C.

If this Parameter is set to 1, the cooling fan keeps working after power-on.

F8-49	Wakeup frequency	Default	0.00Hz
	Setting Range	Dormant frequency (F8-51) to maximum frequency (F0-10)	
F8-50	Wakeup delay time	Default	0.0s
	Setting Range	0.0s ~ 6500.0s	
F8-51	Dormant frequency	Default	0.00Hz
	Setting Range	0.00Hz ~ wakeup frequency (F8-49)	
F8-52	Dormant delay time	Default	0.0s
	Setting Range	0.0s ~ 6500.0s	

These Parameters are used to implement the dormant and wakeup functions in the water supply application.

When the AC drive is in running state, the AC drive enters the dormant state and stops automatically after the dormant delay time (F8-52) if the set frequency is lower than or equal to the dormant frequency (F8-51).

When the AC drive is in dormant state and the current running command is effective, the AC drives starts up after the wakeup delay time (F8-50) if the set frequency is higher than or equal to the wakeup frequency (F8-49).

Generally, set the wakeup frequency equal to or higher than the dormant frequency. If the wakeup frequency and dormant frequency are set to 0, the dormant and wakeup functions are disabled.

When the dormant function is enabled, if the frequency source is PID, whether PID operation is performed in the dormant state is determined by FA-28. In this case, select PID operation enabled in the stop state (FA-28 = 1).

F8-53	Current running time reached	Default	0.0Min
	Setting Range	0.0Min ~ 6500.0Min	

If the current running time reaches the value set in this Parameter, the corresponding DO becomes ON, indicating that the current running time is reached.

7.10 Group F9 Fault and Protection

F9-00	Motor overload protection selection	Default	1
	Setting Range	0	Disabled
		1	Enabled
F9-01	Motor overload protection gain	Default	1
	Setting Range	0.20 ~ 10.00	

F9-00 = 0

The motor overload protective function is disabled. The motor is exposed to potential damage due to overheating. A thermal relay is suggested to be installed between the AC drive and the motor.

F9-00 = 1

The AC drive judges whether the motor is overloaded according to the inverse time-lag curve of the motor overload protection.

The inverse time-lag curve of the motor overload protection is:

$220\% \times F9-01 \times \text{rated motor current}$ (if the load remains at this value for one minute, the AC drive reports motor overload fault), or $150\% \times F9-01 \times \text{rated motor current}$ (if the load remains at this value for 60 minutes, the AC drive reports motor overload fault)

Set F9-01 properly based on the actual overload capacity. If the value of F9-01 is set too large, damage to the motor may result because the motor overheats but the AC drive does not report the alarm.

F9-02	Motor overload warning coefficient	Default	80%
	Setting Range	50% ~ 100%	

This function is used to give a warning signal to the control system via DO before motor overload rotection. This Parameter is used to determine the percentage, at which pre-warning is performed before motor overload. The larger the value is, the less advanced the pre-warning will be.

When the accumulative output current of the AC drive is greater than the value of the overload inverse time-lag curve multiplied by F9-02, the DO terminal on the AC drive allocated with function 6 (Motor overload pre-warning) becomes ON.

F9-03	Overvoltage stall gain	Default	0
	Setting Range	0 (no stall overvoltage) ~ 100	
F9-04	Overvoltage stall protective voltage	Default	130%
	Setting Range	120% ~ 150%	

When the DC bus voltage exceeds the value of F9-04 (Overvoltage stall protective voltage) during deceleration of the AC drive, the AC drive stops deceleration and keeps the present running frequency. After the bus voltage declines, the AC drive continues to decelerate.

F9-03 (Overvoltage stall gain) is used to adjust the overvoltage suppression capacity of the AC drive. The larger the value is, the greater the overvoltage suppression capacity will be.

In the prerequisite of no overvoltage occurrence, set F9-03 to a small value. For small-inertia load, the value should be small. Otherwise, the system dynamic response will be slow. For large-inertia load, the value should be large. Otherwise, the suppression result will be poor and an overvoltage fault may occur.

If the overvoltage stall gain is set to 0, the overvoltage stall function is disabled.

F9-05	Overcurrent stall gain	Default	20
	Setting Range	0 ~ 100	
F9-06	Overcurrent stall protective current	Default	150%
	Setting Range	100% ~ 200%	

When the output current exceeds the overcurrent stall protective current during acceleration/deceleration of the AC drive, the AC drive stops acceleration/deceleration and keeps the present running frequency. After the output current declines, the AC drive continues to

accelerate/decelerate.

F9-05 (Overcurrent stall gain) is used to adjust the overcurrent suppression capacity of the AC drive. The larger the value is, the greater the overcurrent suppression capacity will be. In the prerequisite of no overcurrent occurrence, set F9-05 to a small value.

For small-inertia load, the value should be small. Otherwise, the system dynamic response will be slow. For large-inertia load, the value should be large. Otherwise, the suppression result will be poor and overcurrent fault may occur.

If the overcurrent stall gain is set to 0, the overcurrent stall function is disabled.

F9-07	Short-circuit to ground upon power-on	Default	1
	Setting Range	0: Disabled; 1: Enabled	

It is used to determine whether to check the motor is short-circuited to ground at power-on of the AC drive. If this function is enabled, the AC drive's UVW will have voltage output a while after power-on.

F9-09	Fault auto reset times	Default	0
	Setting Range	0 ~ 20	

It is used to set the times of fault auto resets if this function is used. After the value is exceeded, the AC drive will remain in the fault state.

F9-10	DO action during fault auto reset	Default	0
	Setting Range	0: Not act; 1: Act	

It is used to decide whether the DO acts during the fault auto reset if the fault auto reset function is selected.

F9-11	Time interval of fault auto reset	Default	1.0s
	Setting Range	0.1s ~ 100.0s	

It is used to set the waiting time from the alarm of the AC drive to fault auto reset.

F9-12	Input phase loss protection/contactor energizing protection selection	Default	11
	Setting Range	Unit's digit: Input phase loss protection Ten's digit: Contactor energizing 0: Disabled 1: Enabled	

It is used to determine whether to perform input phase loss or contactor energizing protection. For every voltage class, the SINUS VEGA AC drives of powers equal to or greater than those listed in the preceding table provide the function of input phase loss or contactor energizing

protection. The SINUS VEGA AC drives below the power listed in the table do not have the function no matter whether F9-12 is set to 0 or 1.

F9-13	Output phase loss protection selection	Default	1
	Setting Range	0: Disabled 1: Enabled	

It is used to determine whether to perform output phase loss protection.

F9-14	1st fault type	0 ~ 99
F9-15	2nd fault type	
F9-16	3rd (latest) fault type	

It is used to record the types of the most recent three faults of the AC drive. 0 indicates no fault. For possible causes and solution of each fault, refer to Chapter 8.

F9-17	Frequency upon 3rd fault	It displays the frequency when the latest fault occurs.																				
F9-18	Current upon 3rd fault	It displays the current when the latest fault occurs.																				
F9-19	Bus voltage upon 3rd fault	It displays the bus voltage when the latest fault Occurs.																				
F9-20	Digital Input status upon 3rd fault	<p>It displays the status of all X terminals when the latest fault occurs. The sequence is as follows:</p> <table border="1" style="margin-left: auto; margin-right: auto;"> <tr> <td>BIT9</td><td>BIT8</td><td>BIT7</td><td>BIT6</td><td>BIT5</td><td>BIT4</td><td>BIT3</td><td>BIT2</td><td>BIT1</td><td>BIT0</td> </tr> <tr> <td>DI9</td><td>DI8</td><td>DI7</td><td>DI6</td><td>DI5</td><td>DI4</td><td>DI3</td><td>DI2</td><td>DI1</td><td></td> </tr> </table> <p>If the X terminal is ON, the setting is 1. If the X terminal is OFF, the setting is 0. The value is the equivalent decimal number converted from the X terminal status.</p>	BIT9	BIT8	BIT7	BIT6	BIT5	BIT4	BIT3	BIT2	BIT1	BIT0	DI9	DI8	DI7	DI6	DI5	DI4	DI3	DI2	DI1	
BIT9	BIT8	BIT7	BIT6	BIT5	BIT4	BIT3	BIT2	BIT1	BIT0													
DI9	DI8	DI7	DI6	DI5	DI4	DI3	DI2	DI1														
F9-21	Output terminal status upon 3rd fault	<p>It displays the status of all output terminals when the latest fault occurs. The sequence is as follows:</p> <table border="1" style="margin-left: auto; margin-right: auto;"> <tr> <td>BIT4</td><td>BIT3</td><td>BIT2</td><td>BIT1</td><td>BIT0</td> </tr> <tr> <td>DO2</td><td>DO1</td><td>REL2</td><td>REL1</td><td>FMP</td> </tr> </table> <p>If an output terminal is ON, the setting is 1. If the output terminal is OFF, the setting is 0. The value is the equivalent decimal number converted from the X terminal statuses.</p>	BIT4	BIT3	BIT2	BIT1	BIT0	DO2	DO1	REL2	REL1	FMP										
BIT4	BIT3	BIT2	BIT1	BIT0																		
DO2	DO1	REL2	REL1	FMP																		
F9-22	AC drive status upon 3rd Fault	Reserved																				
F9-23	Power-on time upon 3rd Fault	It displays the present power-on time when the latest fault occurs.																				
F9-24	Running time upon 3rd Fault	It displays the present running time when the latest fault occurs.																				

F9-27	Frequency upon 2nd fault	Same as F9-17 ~ F9-24
F9-28	Current upon 2nd fault	
F9-29	Bus voltage upon 2nd fault	
F9-30	X terminal status upon 2nd fault	
F9-31	Output terminal status upon 2nd fault	
F9-32	Frequency upon 2nd fault	
F9-33	Current upon 2nd fault	
F9-34	Bus voltage upon 2nd fault	
F9-37	X terminal status upon 1st fault	Same as F9-17 ~ F9-24
F9-38	Current upon 1st fault	
F9-39	Bus voltage upon 3rd fault	
F9-40	X terminal status upon 1st fault	
F9-41	Output terminal status upon 1st fault	
F9-42	AC Drive status upon 1 st fault	
F9-43	Output terminal status upon 1st fault	
F9-44	Frequency upon 1st fault	

F9-47	Fault protection action selection 1	Default	00000	
	Setting Range	Unit's digit	Motor overload (Err11)	
		0	Coast to stop	
		1	Stop according to the stop mode	
		2	Continue to run	
		Ten's digit	Power input phase loss (Err12) (Same as unit's digit)	
		Hundred's digit	Power output phase loss (Err13) (Same as unit's digit)	
		Thousand's digit	External equipment fault (Err15) (Same as unit's digit)	
		Ten thousand's digit	Communication fault (Err16) (Same as unit's digit)	

F9-48	Fault protection action selection 2		Default	00000
	Setting Range	Unit's digit	Encoder fault (Err20)	
		0	Coast to stop	
		1	Switch over to V/F control, stop according to the stop mode	
		2	Switch over to V/F control, continue to run	
		Ten's digit	EEPROM read-write fault (Err21)	
		0	Coast to stop	
		1	Stop according to the stop mode	
		Hundred's digit	Reserved	
		Thousand's digit	Motor overheat (Err25) Same as unit's digit in F9-47	
		Ten thousand's digit	Accumulative running time reached (Err26) Same as unit's digit in F9-47	
F9-49	Fault protection action selection 3		Default	00000
	Setting Range	Unit's digit	User-defined fault 1(Err27) Same as unit's digit in F9-47	
		Ten's digit	User-defined fault 2(Err28) Same as unit's digit in F9-47	
		Hundred's digit	Accumulative power-on time reached (Err29) Same as unit's digit in F9-47	
		Thousand's digit	Load becoming 0 (Err30)	
		0	Coast to stop	
		1	Stop according to the stop mode	
		2	Continue to run at 7% of rated motor frequency and resume to the set frequency if the load Recovers	
		Ten thousand's digit	PID feedback lost during running (Err31) Same as unit's digit in F9-47	

F9-50	Fault protection action selection 4		Default	00000
	Setting Range	Unit's digit	Too large speed deviation, (Err42) Same as unit's digit in F9-47	
		Ten's digit	Motor over-speed (Err43) Same as unit's digit in F9-47	
		Hundred's digit	Initial position fault (Err51) Same as unit's digit in F9-47	
		Thousand's digit	Speed feedback fault (Err52) Same as unit's digit in F9-47	
		Ten thousand's digit	Reserved	

If "Coast to stop" is selected, the AC drive displays Err** and directly stops.

If "Stop according to the stop mode" is selected, the AC drive displays A** and stops according to the stop mode. After stop, the AC drive displays Err**.

If "Continue to run" is selected, the AC drive continues to run and displays A**. The running frequency is set in F9-54.

F9-54	Frequency selection for continuing to run upon fault		Default	0
	Setting Range	0	Current running frequency	
		1	Set frequency	
		2	Frequency upper limit	
		3	Frequency lower limit	
		4	Backup frequency upon abnormality	
F9-55	Backup frequency upon abnormality		Default	100.0%
	Setting Range		0.0% ~ 100.0%(maximum frequency)	

If a fault occurs during the running of the AC drive and the handling of fault is set to "Continue to run", the AC drive displays A** and continues to run at the frequency set in F9-54.

The setting of F9-55 is a percentage relative to the maximum frequency.

F9-56	Type of motor temperature sensor		Default	0
	Setting Range	0	No temperature sensor	
		1	PT100	
		2	PT1000	
F9-57	Motor overheat protection threshold		Default	110°C
	Setting Range		0°C ~ 200°C	

F9-58	Motor overheat warning threshold	Default	90°C
	Setting Range	0°C ~ 200°C	

The signal of the motor temperature sensor needs to be connected to the optional I/O extension card. AI3 on the extension card can be used for the temperature signal input.

The motor temperature sensor is connected to AI3 and PGND of the extension card. The AI3 terminal of the SINUS VEGA supports both PT100 and PT1000. Set the sensor type correctly during the use. You can view the motor temperature via C-34.

If the motor temperature exceeds the value set in F9-57, the AC drive reports an alarm and acts according to the selected fault protection action.

If the motor temperature exceeds the value set in F9-58, the DO terminal on the AC drive allocated with function 39 (Motor overheat warning) becomes ON.

F9-59	Action selection at instantaneous power failure	Default	0
	Setting Range	0	Invalid
		1	Decelerate
		2	Decelerate to stop
F9-60	Action Pause judging voltage at instantaneous power failure	Default	90.0%
	Setting Range	80.0% ~ 100.0%	
F9-61	Voltage rally judging time at instantaneous power failure	Default	0.50s
	Setting Range	0.00s ~ 100.00s	
F9-62	Action judging voltage at instantaneous power failure	Default	80.0%
	Setting Range	60.0% ~ 100.0%(standard bus voltage)	

Upon instantaneous power failure or sudden voltage dip, the DC bus voltage of the AC drive reduces. This function enables the AC drive to compensate the DC bus voltage reduction with the load feedback energy by reducing the output frequency so as to keep the AC drive running continuously.

If F9-59 = 1, upon instantaneous power failure or sudden voltage dip, the AC drive decelerates. Once the bus voltage resumes to normal, the AC drive accelerates to the set frequency. If the bus voltage remains normal for the time exceeding the value set in F9-61, it is considered that the bus voltage resumes to normal.

If F9-59 = 2, upon instantaneous power failure or sudden voltage dip, the AC drive decelerates to stop.

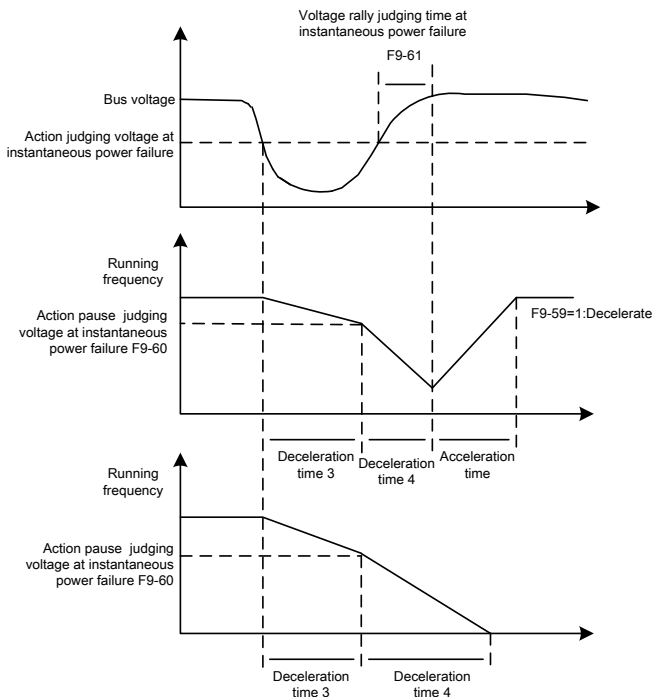

Figure 6-24 AC drive action diagram upon instantaneous power failure

F9-63	Protection upon load becoming 0	Default	0
	Setting Range	0	Disabled
		1	Enabled
F9-64	Detection level of load becoming 0	Default	10.0%
	Setting Range	0.0% ~ 100.0% (rated motor current)	
F9-65	Detection time of load becoming 0	Default	1.0s
	Setting Range	0.0s ~ 60.0s	

If protection upon load becoming 0 is enabled, when the output current of the AC drive is lower than the detection level (F9-64) and the lasting time exceeds the detection time (F9-65), the output frequency of the AC drive automatically declines to 7% of the rated frequency. During the protection, the AC drive automatically accelerates to the set frequency if the load resumes to normal.

F9-67	Over-speed detection value	Default	20.0%
	Setting Range	0.0% ~ 50.0% (maximum frequency)	
F9-68	Over-speed detection time	Default	1.0s
	Setting Range	0.0s ~ 60.0s	

This function is valid only when the AC drive runs in the FVC mode. If the actual motor rotational speed detected by the AC drive exceeds the maximum frequency and the excessive value is greater than the value of F9-67 and the lasting time exceeds the value of F9-68, the AC drive reports Err43 and acts according to the selected fault protection action.

If the over-speed detection time is 0.0s, the over-speed detection function is disabled.

F9-69	Detection value of too large speed deviation	Default	20.0%
	Setting Range	0.0% ~ 50.0%(maximum frequency)	
F9-70	Detection time of too large speed deviation	Default	5.0s
	Setting Range	0.0s ~ 60.0s	

This function is valid only when the AC drive runs in the FVC mode. If the AC drive detects the deviation between the actual motor rotational speed detected by the AC drive and the set frequency is greater than the value of F9-69 and the lasting time exceeds the value of F9-70, the AC drive reports Err42 and according to the selected fault protection action.

If F9-70 (Detection time of too large speed deviation) is 0.0s, this function is disabled.

7.11 Group FA: Process Control PID Function

PID control is a general process control method. By performing proportional, integral and differential operations on the difference between the feedback signal and the target signal, it adjusts the output frequency and constitutes a feedback system to stabilize the controlled counter around the target value.

It is applied to process control such as flow control, pressure control and temperature control. The following figure shows the principle block diagram of PID control.

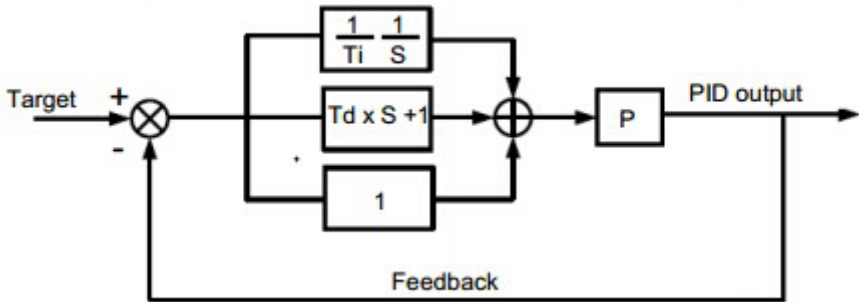

Figure 6-25 Principle block diagram of PID control

FA-00	PID setting source	Default	0
	Setting Range	0	FA-01 Setting
		1	AI1
		2	AI2
		3	AI3
		4	PULSE Pulse (X5)
		5	Communication
6	Multi-reference		
FA-01	PID digital setting	Default	50.0%
	Setting range	0.0% ~ 100.0%	

FA-00 is used to select the channel of target process PID setting. The PID setting is a relative value and ranges from 0.0% to 100.0%. The PID feedback is also a relative value.

The purpose of PID control is to make the PID setting and PID feedback equal.

FA-02	PID Feedback source	Default	0
	Setting range	0	AI1
		1	AI2
		2	AI3
		3	AI1 - AI2
		4	PULSE Pulse (X5)
		5	Communication
		6	AI1+AI2
		7	MAX(AI1 , AI2)
8	MIN (AI1 , AI2)		

This Parameter is used to select the feedback signal channel of process PID.

The PID feedback is a relative value and ranges from 0.0% to 100.0%.

FA-03	PID action direction		Default	0
	Setting range	0	Forward action	
		1	Reverse action	

0: Forward action

When the feedback value is smaller than the PID setting, the AC drive's output frequency rises. For example, the winding tension control requires forward PID action.

1: Reverse action

When the feedback value is smaller than the PID setting, the AC drive's output frequency reduces. For example, the unwinding tension control requires reverse PID action.

Note that this function is influenced by the X function 35 "Reverse PID action direction".

FA-04	PID setting feedback range		Default	1000
	Setting range		0 ~ 65535	

This Parameter is a non-dimensional unit. It is used for PID setting display (C-15) and PID feedback display (C-16).

Relative value 100% of PID setting feedback corresponds to the value of FA-04. If FA-04 is set to 2000 and PID setting is 100.0%, the PID setting display (C-15) is 2000.PID

FA-05	Proportional gain KF1		Default	20.0
	Setting range		0.0 ~ 100.0	
FA-06	Integral time Ti1		Default	2.00s
	Setting range		0.01s ~ 10.00s	
FA-07	Differential timeTd1		Default	0.000s
	Setting range		0.00 ~ 10.000	

FA-05 (Proportional gain KF1)

It decides the regulating intensity of the PID regulator. The higher the KF1 is, the larger the regulating intensity is. The value 100.0 indicates when the deviation between PID feedback and PID setting is 100.0%, the adjustment amplitude of the PID regulator on the output frequency reference is the maximum frequency.

FA-06 (Integral time Ti1)

It decides the integral regulating intensity. The shorter the integral time is, the larger the regulating intensity is. When the deviation between PID feedback and PID setting is 100.0%, the integral regulator performs continuous adjustment for the time set in FA-06. Then the adjustment amplitude reaches the maximum frequency.

FA-07 (Differential time Td1)

It decides the regulating intensity of the PID regulator on the deviation change. The longer the differential time is, the larger the regulating intensity is. Differential time is the time within which the feedback value change reaches 100.0%, and then the adjustment amplitude reaches the maximum frequency.

FA-08	Cut-off frequency of PID reverse rotation	Default	2.00Hz
	Setting range	0. 00 ~Max frequency	

In some situations, only when the PID output frequency is a negative value (AC drive reverse rotation), PID setting and PID feedback can be equal. However, too high reverse rotation frequency is prohibited in some applications, and FA-08 is used to determine the reverse rotation frequency upper limit.

FA-09	PID deviation limit	Default	0.0%
	Setting range	0. 0% ~ 100.0%	

If the deviation between PID feedback and PID setting is smaller than the value of FA-09, PID control stops. The small deviation between PID feedback and PID setting will make the output frequency stabilize, effective for some closed-loop control applications.

FA-10	PID deviation limit	Default	0.10%
	Setting range	0. 00% ~ 100.00%	

It is used to set the PID differential output range. In PID control, the differential operation may easily cause system oscillation. Thus, the PID differential regulation is restricted to a small range.

FA-11	PID setting change time	Default	0.00s
	Setting range	0.00s ~ 650.00s	

The PID setting change time indicates the time required for PID setting changing from 0.0% to 100.0%. The PID setting changes linearly according to the change time, reducing the impact caused by sudden setting change on the system.

FA-12	PID feedback filter time	Default	0.00s
	Setting range	0.00s ~ 60.00s	
FA-13	PID output filter time	Default	0.00s
	Setting range	0.00s ~ 60.00s	

FA-12 is used to filter the PID feedback, helping to reduce interference on the feedback but slowing the response of the process closed-loop system.

FA-13 is used to filter the PID output frequency, helping to weaken sudden change of the AC drive output frequency but slowing the response of the process closed-loop system.

FA-15	Proportional gain KF2		Default	20.0
	Setting range		0.0 ~ 100.0	
FA-16	Integral time Ti2		Default	2.00s
	Setting range		0.01s ~ 10.00s	
FA-17	Differential time Td2		Default	0.000s
	Setting range		0.00 ~ 10.000	
FA-18	PID Parameter switchover condition		Default	0
	Setting range	0	No switchover	
		1	Switchover via X	
		2	Automatic switchover based on deviation	
FA-19	PID Parameter switchover deviation 1		Default	20.0%
	Setting range		0.0% ~ FA-20	
FA-20	PID Parameter switchover deviation 2		Default	80.0%
	Setting range		FA-19 ~ 100.0%	

In some applications, PID Parameters switchover is required when one group of PID Parameters cannot satisfy the requirement of the whole running process.

These Parameters are used for switchover between two groups of PID Parameters. Regulator Parameters FA-15 to FA-17 are set in the same way as FA-05 to FA-07.

The switchover can be implemented either via a X terminal or automatically implemented based on the deviation.

If you select switchover via a X terminal, the X must be allocated with function 43 "PID Parameter switchover". If the X is OFF, group 1 (FA-05 to FA-07) is selected. If the X is ON, group 2 (FA-15 to FA-17) is selected.

If you select automatic switchover, when the absolute value of the deviation between PID feedback and PID setting is smaller than the value of FA-19, group 1 is selected. When the absolute value of the deviation between PID feedback and PID setting is higher than the value of FA-20, group 2 is selected. When the deviation is between FA-19 and FA-20, the PID

Parameters are the linear interpolated value of the two groups of Parameter values.

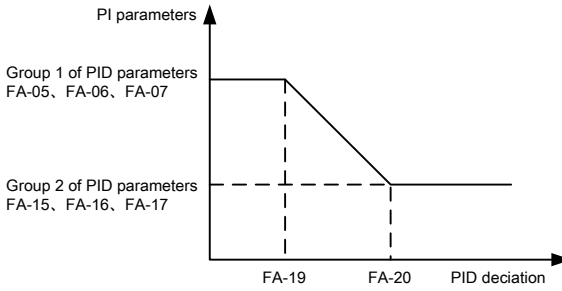

Figure 6-26 PID Parameters switchover

FA-21	PID initial value	Default	0.0%
	Setting range	0.0% ~ 100.0%	
FA-22	PID initial value holding time	Default	0.00s
	Setting range	0.00s ~ 650.00s	

When the AC drive starts up, the PID starts closed-loop algorithm only after the PID output is fixed to the PID initial value (FA-21) and lasts the time set in FA-22.

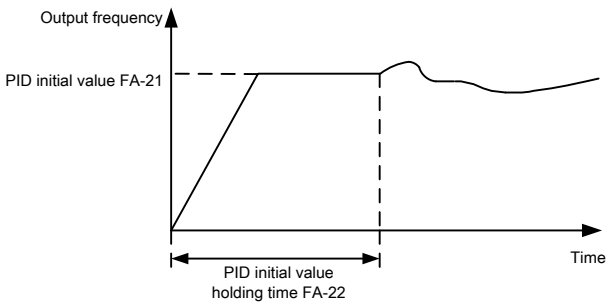

Figure 6-27 PID initial value function

FA-23	Maximum deviation between two PID outputs in forward direction	Default	1.00%
	Setting range	0.00% ~ 100.00%	
FA-24	Maximum deviation between two PID outputs in reverse direction	Default	1.00%
	Setting range	0.00% ~ 100.00%	

This function is used to limit the deviation between two PID outputs (2 ms per PID output) to suppress the rapid change of PID output and stabilize the running of the AC drive.

FA-23 and FA-24 respectively correspond to the maximum absolute value of the output deviation in forward direction and in reverse direction.

FA-25	PID integral property		Default	00
	Setting range	Unit's digit	Integral separated	
		0	Invalid	
		1	Valid	
		Ten's digit	Whether to stop integral operation when the output reaches the limit	
		0	Continue integral operation	
1	Stop integral operation			

Integral separated

If it is set to valid, , the PID integral operation stops when the X allocated with function 38 "PID integral Pause" is ON In this case, only proportional and differential operations take effect.

If it is set to invalid, integral separated remains invalid no matter whether the X allocated with function 38 "PID integral Pause" is ON or not.

Whether to stop integral operation when the output reaches the limit

If "Stop integral operation" is selected, the PID integral operation stops, which may help to reduce the PID overshoot.

FA-26	Detection value of PID feedback loss	Default	0.0%
	Setting range	0.0%: Not judging feedback loss; 0.1% ~ 100.0%	
FA-27	Detection time of PID feedback loss	Default	0.0s
	Setting range	0.0s ~ 20.0s	

These Parameters are used to judge whether PID feedback is lost.

If the PID feedback is smaller than the value of FA-26 and the lasting time exceeds the value of FA-27, the AC drive reports Err31 and acts according to the selected fault protection action.

FA-28	PID operation at stop		Default	0
	Setting range	0	No PID operation at stop	
		1	PID operation at stop	

It is used to select whether to continue PID operation in the state of stop. Generally, the PID operation stops when the AC drive stops.

7.12 Group FB: Swing Frequency, Fixed Length and Count

The swing frequency function is applied to the textile and chemical fiber fields and the applications where traversing and winding functions are required.

The swing frequency function indicates that the output frequency of the AC drive swings up and down with the set frequency as the center. The trace of running frequency at the time axis is shown in the following figure.

The swing amplitude is set in FB-00 and FB-01. When FB-01 is set to 0, the swing amplitude is 0 and the swing frequency does not take effect.

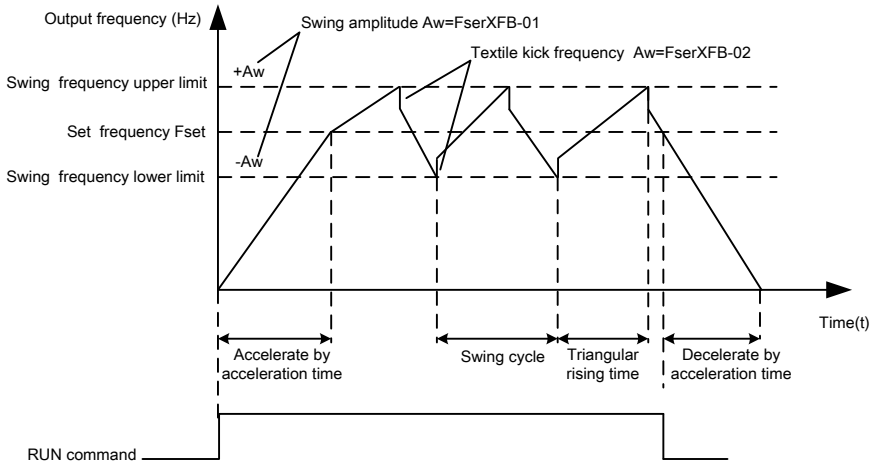

Figure 6-28 Swing frequency control

FB-00	Swing frequency setting mode	Default	0
	Setting range	0	Relative to the central frequency
		1	Relative to the maximum frequency

This Parameter is used to select the base value of the swing amplitude.

0: Relative to the central frequency (F0-07 frequency source selection)

It is variable swing amplitude system. The swing amplitude varies with the central frequency (set frequency).

1: Relative to the maximum frequency (F0-10 maximum output frequency)

It is fixed swing amplitude system. The swing amplitude is fixed.

FB-01	Swing frequency amplitude	Default	0.0%
	Setting range	0.0% ~ 100.0%	
FB-02	Jump frequency amplitude	Default	0.0%
	Setting range	0.0% ~ 50.0%	

This Parameter is used to determine the swing amplitude and jump frequency amplitude.

The swing frequency is limited by the frequency upper limit and frequency lower limit.

If relative to the central frequency (FB-00 = 0), the actual swing amplitude AW is the calculation result of F0-07 (Frequency source selection) multiplied by FB-01.

If relative to the maximum frequency (FB-00 = 1), the actual swing amplitude AW is the calculation result of F0-10 (Maximum frequency) multiplied by FB-01.

Jump frequency = Swing amplitude AW x FB-02 (Jump frequency amplitude).

If relative to the central frequency (FB-00 = 0), the jump frequency is a variable value.

If relative to the maximum frequency (FB-00 = 1), the jump frequency is a fixed value.

The swing frequency is limited by the frequency upper limit and frequency lower limit.

FB-03	Swing frequency cycle	Default	10.0s
	Setting range	0.0s ~ 3000.0s	
FB-04	Triangular wave rising time coefficient	Default	50.0%
	Setting range	0.0% ~ 100.0%	

FB-03 specifies the time of a complete swing frequency cycle.

FB-04 specifies the time percentage of triangular wave rising time to FB-03 (Swing frequency cycle).

Triangular wave rising time = FB-03 (Swing frequency cycle) x FB-04 (Triangular wave rising time coefficient, unit: s)

Triangular wave falling time = FB-03 (Swing frequency cycle) x (1 – FB-04 Triangular wave rising time coefficient, unit: s)

FB-05	Setting Length	Default	1000m
	Setting range	0m ~ 65535m	
FB-06	Actual Length	Default	0m
	Setting range	0m ~ 65535m	
FB-07	Pulse/meter	Default	100.0
	Setting range	0.1 ~ 6553.5	

The preceding Parameters are used for fixed length control.

The length information is collected by X terminals. FB-06 (Actual length) is calculated by dividing the number of pulses collected by the X terminal by FB-07 (Number of pulses each

meter).

When the actual length FB-06 exceeds the set length in FB-05, the DO terminal allocated with function 10 (Length reached) becomes ON.

During the fixed length control, the length reset operation can be performed via the X terminal allocated with function 28. For details, see the descriptions of F4-00 to F4-09.

Allocate corresponding X terminal with function 27 (Length count input) in applications. If the pulse frequency is high, X5 must be used.

FB-08	Set count value	Default	1000
	Setting range	1 ~ 65535	
FB-09	Designated count value	Default	1000
	Setting range	1 ~ 65535	

The count value needs to be collected by X terminal. Allocate the corresponding X terminal with function 25 (Counter input) in applications. If the pulse frequency is high, X5 must be used.

When the count value reaches the set count value (FB-08), the DO terminal allocated with function 8 (Set count value reached) becomes ON. Then the counter stops counting.

When the counting value reaches the designated counting value (FB-09), the DO terminal allocated with function 9 (Designated count value reached) becomes ON. Then the counter continues to count until the set count value is reached.

FB-09 should be equal to or smaller than FB-08.

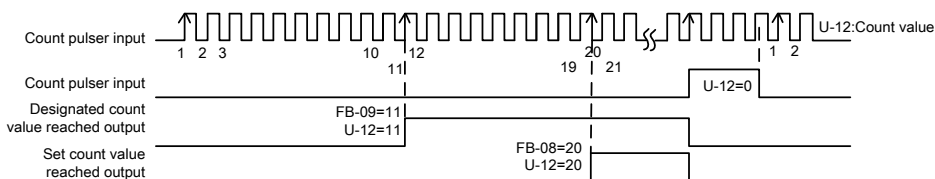

Figure 6-29 Reaching the set count value and designated count value

7.13 Group FC: Multi-Reference and Simple PLC Function

The SINUS VEGA multi-reference has many functions. Besides multi-speed, it can be used as the setting source of the V/F separated voltage source and setting source of process PID. In addition, the multi-reference is relative value.

The simple PLC function is different from the SINUS VEGA user programmable function. Simple

PLC can only complete simple combination of multi-reference, while the user programmable function is more practical. For details, see the descriptions of group.

FC-00	Multi-reference 0	Default	0.0%
	Setting range	-100.0% ~ 100.0%	
FC-01	Multi-reference 1	Default	0.0%
	Setting range	-100.0% ~ 100.0%	
FC-02	Multi-reference 2	Default	0.0%
	Setting range	-100.0% ~ 100.0%	
FC-03	Multi-reference 3	Default	0.0%
	Setting range	-100.0% ~ 100.0%	
FC-04	Multi-reference 4	Default	0.0%
	Setting range	-100.0% ~ 100.0%	
FC-05	Multi-reference 5	Default	0.0%
	Setting range	-100.0% ~ 100.0%	
FC-06	Multi-reference 6	Default	0.0%
	Setting range	-100.0% ~ 100.0%	
FC-07	Multi-reference 7	Default	0.0%
	Setting range	-100.0% ~ 100.0%	
FC-08	Multi-reference 8	Default	0.0%
	Setting range	-100.0% ~ 100.0%	
FC-09	Multi-reference 9	Default	0.0%
	Setting range	-100.0% ~ 100.0%	
FC-10	Multi-reference 10	Default	0.0Hz
	Setting range	-100.0% ~ 100.0%	
FC-11	Multi-reference 11	Default	0.0%
	Setting range	-100.0% ~ 100.0%	
FC-12	Multi-reference 12	Default	0.0%
	Setting range	-100.0% ~ 100.0%	
FC-13	Multi-reference 13	Default	0.0%
	Setting range	-100.0% ~ 100.0%	
FC-14	Multi-reference 14	Default	0.0%
	Setting range	-100.0% ~ 100.0%	
FC-15	Multi-reference 15	Default	0.0%
	Setting range	-100.0% ~ 100.0%	

Multi-reference can be the setting source of frequency, V/F separated voltage and process PID. The multi-reference is relative value and ranges from -100.0% to 100.0%.

As frequency source, it is a percentage relative to the maximum frequency. As V/F separated voltage source, it is a percentage relative to the rated motor voltage. As process PID setting source, it does not require conversion.

Multi-reference can be switched over based on different states of X terminals. For details, see the descriptions of group F4.

FC-16	Simple PLC running mode	Default	0
	Setting range	0	Stop after the AC drive runs one cycle
		1	Keep final values after the AC drive runs
		2	Repeat after the AC drive runs one cycle

0: Stop after the AC drive runs one cycle

The AC drive stops after running one cycle, and will not start up until receiving another command.

1: Keep final values after the AC drive runs one cycle

The AC drive keeps the final running frequency and direction after running one cycle.

2: Repeat after the AC drive runs one cycle

The AC drive automatically starts another cycle after running one cycle, and will not stop until receiving the stop command.

Simple PLC can be either the frequency source or V/F separated voltage source.

When simple PLC is used as the frequency source, whether Parameter values of FC-00 to FC-15 are positive or negative determines the running direction. If the Parameter values are negative, it indicates that the AC drive runs in reverse direction.

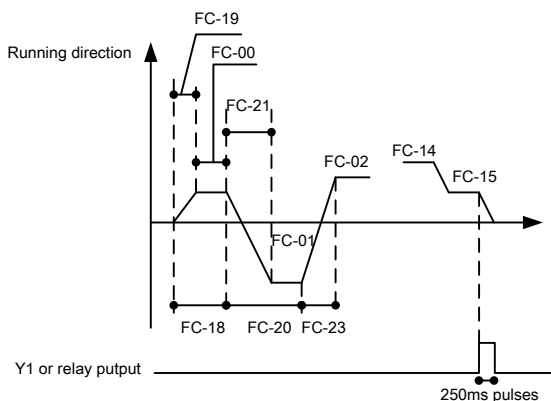

Figure 6-32 Simple PLC when used as frequency source

FC-17	Simple PLC retentive selection		Default	00
	Setting range	Unit's digit	Retentive upon power failure	
		0	No	
		1	Yes	
		Ten's digit	Retentive upon stop	
		0	No	
1	Yes			

PLC retentive upon power failure indicates that the AC drive memorizes the PLC running moment and running frequency before power failure and will continue to run from the memorized moment after it is powered on again. If the unit's digit is set to 0, the AC drive restarts the PLC process after it is powered on again.

PLC retentive upon stop indicates that the AC drive records the PLC running moment and running frequency upon stop and will continue to run from the recorded moment after it starts up again. If the ten's digit is set to 0, the AC drive restarts the PLC process after it starts up again.

FC-18	Running time of simple PLC reference 0	Default	0.0s(h)
	Setting range	0.0s(h) ~ 6553.5s(h)	
FC-19	Acceleration/deceleration time of simple PLC reference 0	Default	0
	Setting range	0 ~ 3	
FC-20	Running time of simple PLC reference 1	Default	0.0s(h)
	Setting range	0.0s(h) ~ 6553.5s(h)	
FC-21	Acceleration/deceleration time of simple PLC reference 1	Default	0
	Setting range	0 ~ 3	
FC-22	Running time of simple PLC reference 2	Default	0.0s(h)
	Setting range	0.0s(h) ~ 6553.5s(h)	
FC-23	Acceleration/deceleration time of simple PLC reference 2	Default	0
	Setting range	0 ~ 3	

FC-24	Running time of simple PLC reference 3	Default	0.0s(h)
	Setting range	0.0s(h) ~ 6553.5s(h)	
FC-25	Acceleration/deceleration time of simple PLC reference 3	Default	0
	Setting range	0 ~ 3	
FC-26	Running time of simple PLC reference 4	Default	0.0s(h)
	Setting range	0.0s(h) ~ 6553.5s(h)	
FC-27	Acceleration/deceleration time of simple PLC reference 4	Default	0
	Setting range	0 ~ 3	
FC-28	Running time of simple PLC reference 5	Default	0.0s(h)
	Setting range	0.0s(h) ~ 6553.5s(h)	
FC-29	Acceleration/deceleration time of simple PLC reference 5	Default	0
	Setting range	0 ~ 3	
FC-30	Running time of simple PLC reference 6	Default	0.0s(h)
	Setting range	0.0s(h) ~ 6553.5s(h)	
FC-31	Acceleration/deceleration time of simple PLC reference 6	Default	0
	Setting range	0 ~ 3	
FC-32	Running time of simple PLC reference 7	Default	0.0s(h)
	Setting range	0.0s(h) ~ 6553.5s(h)	
FC-33	Acceleration/deceleration time of simple PLC reference 7	Default	0
	Setting range	0 ~ 3	
FC-34	Running time of simple PLC reference 8	Default	0.0s(h)
	Setting range	0.0s(h) ~ 6553.5s(h)	
FC-35	Acceleration/deceleration time of simple PLC reference 8	Default	0
	Setting range	0 ~ 3	
FC-36	Running time of simple PLC reference 9	Default	0.0s(h)
	Setting range	0.0s(h) ~ 6553.5s(h)	

FC-37	Acceleration/deceleration time of simple PLC reference 9	Default	0
	Setting range	0 ~ 3	
FC-38	Running time of simple PLC reference 10	Default	0.0s(h)
	Setting range	0.0 s(h) ~ 6553.5s(h)	
FC-39	Acceleration/deceleration time of simple PLC reference 10	Default	0
	Setting range	0 ~ 3	
FC-40	Running time of simple PLC reference 11	Default	0.0s(h)
	Setting range	0.0s(h) ~ 6553.5s(h)	
FC-41	Acceleration/deceleration time of simple PLC reference 11	Default	0
	Setting range	0 ~ 3	
FC-42	Running time of simple PLC reference 12	Default	0.0s(h)
	Setting range	0.0s(h) ~ 6553.5s(h)	
FC-43	Acceleration/deceleration time of simple PLC reference 12	Default	0
	Setting range	0 ~ 3	
FC-44	Running time of simple PLC reference 13	Default	0.0s(h)
	Setting range	0.0s(h) ~ 6553.5s(h)	
FC-45	Acceleration/deceleration time of simple PLC reference 13	Default	0
	Setting range	0 ~ 3	
FC-46	Running time of simple PLC reference 14	Default	0.0s(h)
	Setting range	0.0s(h) ~ 6553.5s(h)	
FC-47	Acceleration/deceleration time of simple PLC reference 14	Default	0
	Setting range	0 ~ 3	
FC-48	Running time of simple PLC reference 15	Default	0.0s(h)
	Setting range	0.0s(h) ~ 6553.5s(h)	
FC-49	Acceleration/deceleration time of simple PLC reference 15	Default	0
	Setting range	0 ~ 3	

FC-50	Time unit of simple PLC running	Default	0
	Setting range	0	S (Second)
		1	H (Hours)

FC-51	Reference 0 source	Default	0
	Setting range	0	Set by FC-OO
		1	AI1
		2	AI2
		3	AI3
		4	PULSE Pulse
		5	PID
6	Set by preset frequency (F0-08), modified via terminal UP/DOWN		

It determines the setting channel of reference 0. You can perform convenient switchover between the setting channels. When multi-reference or simple PLC is used as frequency source, the switchover between two frequency sources can be realized easily.

7.14 Group FD: Communication Parameters

Please refer to the "SINUS VEGA communication protocol".

7.15 Group FP: User's Password

FP-00	User's Password	Default	0
	Setting range	0 ~ 65535	

If it is set to any non-zero number, the password protection function is enabled. After a password has been set and taken effect, you must enter the correct password in order to enter the menu. If the entered password is incorrect you cannot view or modify parameters.

If FP-00 is set to 00000, the previously set user password is cleared, and the password protection function is disabled.

FP-01	Restore default settings	Default	0
	Setting range	0	No option settings
		1	Restore factory settings except motor parameters
		2	Clear records

1: Restore default settings except motor parameters

If FP-01 is set to 1, most function codes are restored to the default settings except motor

parameters, frequency reference resolution (F0-22), fault records, accumulative running time (F7-09), accumulative power-on time (F7-13) and accumulative power consumption (F7-14).

2: Clear records

If FP-01 is set to 2, the fault records, accumulative running time (F7-09), accumulative power-on time (F7-13) and accumulative power consumption F7-14) are cleared.

501: Back up current user Parameters

If FP-01 is set to 501, the current parameter settings are backed up, helping you to restore the setting if incorrect parameter setting is performed.

4: Restore user backup Parameters

If FP-01 is set to 4, the previous backup user Parameters are restored.

FP-02	AC drive parameter display property		Default	11
	Setting range	Unit's digit	Group U display selection	
		0	No display	
		1	Display	
		Ten's digit	Group A display selection	
		0	No display	
1		Display		
FP-03	Individualized parameter display property		Default	00
	Setting range	Unit's digit	User-defined parameter display selection	
		0	No display	
		1	Display	
		Ten's digit	User-modified parameter display selection	
		0	No display	
1		Display		

The setting of Parameter display mode aims to facilitate you to view different types of Parameters based on actual requirements. The SINUS VEGA provides the following three parameter display modes.

Parameter Name	Description
AC drive Parameter display	Display function codes of the AC drive in sequence of F0 to PF, A0 to AF and C Group.
User-defined Parameter display	Display a maximum of 32 user-defined Parameters included in group PE.
User-modified Parameter display	Display the Parameters that are modified.

If one digit of FP-03 is set to 1, you can switch over to different Parameter display modes by pressing key QUICK. By default, the AC drive Parameter display mode is used.

The display codes of different Parameter types are shown in the following table.

Parameter Display Mode	Display
AC drive parameter	- b A S E
User-defined parameter	- U S E r
User-modified parameter	- - [- -

The SINUS VEGA provides display of two types of individualized Parameters: user-defined Parameters and user-modified Parameters.

YoC-defined Parameters are included in group PE. You can add a maximum of 32 Parameters, convenient for commissioning.

In user-defined Parameter mode, symbol "u" is added before the function code. For example, F1-00 is displayed as uF1-00.

YoC-modified Parameters are grouped together, convenient for on-site troubleshooting.

In yoC-modified Parameter mode, symbol "c" is added before the function code. For example, F1-00 is displayed as cF1-00.

FP-04	Parameter modification property		Default	0
	Setting range	0	Modifiable	
		1	Not modifiable	

It is used to set whether the Parameters are modifiable to avoid mal-function. If it is set to 0, all Parameters are modifiable. If it is set to 1, all Parameters can only be viewed.

7.16 Group A0: Torque Control and Restricting Parameters

A0-00	Speed/Torque control selection	Default	0
	Setting range	0	Speed control
1		Torque Control	

It is used to select the AC drive's control mode: speed control or torque control.

The SINUS VEGA provides X terminals with two torque related functions, function 29 (Torque control prohibited) and function 46 (Speed control/Torque control switchover). The two X terminals need to be used together with A0-00 to implement speed control/torque control switchover.

If the X terminal allocated with function 46 (Speed control/Torque control switchover) is OFF, the control mode is determined by A0-00. If the X terminal allocated with function 46 is ON, the control mode is reverse to the value of A0-00.

However, if the X terminal with function 29 (Torque control prohibited) is ON, the AC drive is fixed to run in the speed control mode.

A0-01	Torque setting source in torque control	Default	0
	Setting range	0	Digital Setting (A0-03)
		1	AI1
		2	AI2
		3	AI3
		4	PULSE Pulse (X5)
		5	Communication setting
		6	MIN(AI1, AI2)
7	MAX(AI1, AI2)		
A0-03	Torque digital setting in torque control	Default	150.0%
	Setting range	-200.0% ~ 200.0%	

A0-01 is used to set the torque setting source. There are a total of eight torque setting sources.

The torque setting is a relative value. 100.0% corresponds to the AC drive's rated torque.

The setting range is -200.0% to 200.0%, indicating the AC drive's maximum torque is twice of the AC drive's rated torque. A0-01 is used to select torque setting; there are 8 types of torque setting modes.

When torque Setting use mode1~7, communication, analog input, Pulse input100% to A0-03.

A0-05	Forward maximum frequency in torque control	Default	50.00Hz
	Setting range	0.00Hz ~ Max frequency (F0-10)	
A0-06	Reverse maximum frequency in torque control	Default	50.00Hz
	Setting range	0.00Hz ~ Max frequency (F0-10)	

Two Parameters are used to set the maximum frequency in forward or reverse rotation in torque control mode.

In torque control, if the load torque is smaller than the motor output torque, the motor's rotational speed will rise continuously. To avoid runaway of the mechanical system, the motor maximum rotating speed must be limited in torque control.

You can implement continuous change of the maximum frequency in torque control dynamically by controlling the frequency upper limit.

A0-07	Acceleration time in torque control	Default	0.00s
	Setting range	0.00s ~ 65000s	
A0-08	Deceleration time in torque control	Default	0.00s
	Setting range	0.00s ~ 65000s	

In torque control, the difference between the motor output torque and the load torque determines the speed change rate of the motor and load. The motor rotational speed may change quickly and this will result in noise or too large mechanical stress. The setting of acceleration/deceleration time in torque control makes the motor rotational speed change softly.

However, in applications requiring rapid torque response, set the acceleration/deceleration time in torque control to 0.00s. For example, two AC drives are connected to drive the same load. To balance the load allocation, set one AC drive as master in speed control and the other as slave in torque control. The slave receives the master's output torque as the torque command and must follow the master rapidly. In this case, the acceleration/deceleration time of the slave in torque control is set to 0.0s.

7.17 Group A2 to A4: Motor 2 to Motor 4 Parameters

The SINUS VEGA can switch over the running among four motors. For the four motors, you can:

- Set motor nameplate parameters respectively
- Perform motor parameter auto-tuning respectively
- Select V/F control or vector control respectively
- Set encoder-related parameters respectively
- Set parameters related to V/F control or vector control independently

Groups A2, A3 and A4 respectively correspond to motor 2, motor 3 and motor 4. The parameters of the three groups are the same. Here we just list the parameters of group A2 for reference.

All parameters in group A2 have the same definition and usage as parameters of motor 1. For more details, refer to the descriptions of motor 1 parameters.

Function code	Parameter Name	Setting Range	Default
A2-00	Motor type selection	0: Common asynchronous motor 1: Variable frequency asynchronous motor 2: Permanent magnetic synchronous motor	0
A2-01	Rated motor power	0.1–1000.0 kW	Model dependent
A2-02	Rated motor voltage	1–2000 V	Model dependent
A2-03	Rated motor current	0.01–655.35 A (AC drive power ≤ 55 kW) 0.1–6553.5 A (AC drive power > 55 kW)	Model dependent
A2-04	Rated motor frequency	0.01 Hz to maximum frequency	Model dependent
A2-05	Rated motor rotational speed	1–65535 RPM	Model dependent
A2-06	Stator resistance (asynchronous motor)	0.001–65.535 Ω (AC drive power ≤ 55 kW) 0.0001–6.5535 Ω (AC drive power > 55 kW)	Model dependent
A2-07	Rotor resistance (asynchronous motor)	0.001–65.535 Ω (AC drive power ≤ 55 kW) 0.0001–6.5535 Ω (AC drive power > 55 kW)	Model dependent
A2-08	Leakage inductive reactance (asynchronous motor)	0.01–655.35 mH (AC drive power ≤ 55 kW) 0.001–65.535 mH (AC drive power > 55 kW)	Model dependent
A2-09	Mutual inductive reactance (asynchronous motor)	0.1–6553.5 mH (AC drive power ≤ 55 kW) 0.01–655.35 mH (AC drive power > 55 kW)	Model dependent
A2-10	No-load current (asynchronous motor)	0.01 A to A2-03 (AC drive power ≤ 55 kW) 0.1 A to A2-03 (AC drive power > 55 kW)	Model dependent
A2-16	Stator resistance (synchronous motor)	0.001–65.535 Ω (AC drive power ≤ 55 kW) 0.0001–6.5535 Ω (AC drive power > 55 kW)	Model dependent
A2-17	Shaft D inductance (synchronous motor)	0.01–655.35 mH (AC drive power ≤ 55 kW) 0.001–65.535 mH (AC drive power > 55 kW)	Model dependent
A2-18	Shaft Q inductance (synchronous motor)	0.01–655.35 mH (AC drive power ≤ 55 kW) 0.001–65.535 mH (AC drive power > 55 kW)	Model dependent

Function code	Parameter Name	Setting Range	Default
A2-20	Back EMF (synchronous motor)	0.1–6553.5 V	Model dependent
A2-27	Encoder pulses per revolution	1–65535	1024
A2-28	Encoder type	0: ABZ incremental encoder 1: UVW incremental encoder	0
A2-30	A, B phase sequence of ABZ incremental encoder	0: Forward 1: Reserve	0
A2-31	Encoder installation angle	0.0°–359.9°	0.0°
A2-32	U, V, W phase sequence of UVW encoder	0: Forward 1: Reverse	0
A2-33	UVW encoder angle offset	0.0°–359.9°	0.0°
A2-34	Number of pole pairs of resolver	1–65535	1
A2-36	Encoder wire-break fault detection time	0.0s: No action 0.1–10.0s	0.0s
A2-37	Auto-tuning selection	0: No auto-tuning 1: Asynchronous motor static auto-tuning 2: Asynchronous motor complete autotuning 11: Synchronous motor with-load autotuning 12: Synchronous motor no-load auto-tuning	0
A2-38	Speed loop proportional gain 1	0–100	30
A2-39	Speed loop integral time 1	0.01–10.00s	0.50s
A2-40	Switchover frequency 1	0.00 to A2-43	5.00 Hz
A2-41	Speed loop proportional gain 2	0–100	15
A2-42	Speed loop integral time 2	0.01–10.00s	1.00s

Function code	Parameter Name	Setting Range	Default
A2-43	Switchover frequency 2	A2-40 to maximum output frequency	10.00 Hz
A2-44	Vector control slip gain	50%–200%	100%
A2-45	Time constant of speed loop filter	0.000–0.100s	0.000s
A2-46	Vector control overexcitation gain	0–200	64
A2-47	Torque upper limit source in speed control mode	0: A2-48 1: AI1 2: AI2 3: AI3 4: Pulse setting (X5) 5: Via communication 6: MIN(AI1,AI2) 7: MIN(AI1,AI2)	0
A2-48	Digital setting of torque upper limit in speed control mode	0.0%–200.0%	150.0%
A2-51	Excitation adjustment proportional gain	0–20000	2000
A2-52	Excitation adjustment integral gain	0–20000	1300
A2-53	Torque adjustment proportional gain	0–20000	2000
A2-54	Torque adjustment integral gain	0–20000	1300
A2-55	Speed loop integral property	Unit's digit: Integral separated 0: Disabled 1: Enabled	0
A2-56	Field weakening mode of synchronous motor	0: No field weakening 1: Direct calculation 2: Adjustment	0

Function code	Parameter Name	Setting Range	Default
A2-57	Field weakening degree of synchronous motor	50%–500%	100%
A2-58	Maximum field weakening current	1%–300%	50%
A2-59	Field weakening automatic adjustment gain	10%–500%	100%
A2-60	Field weakening integral multiple	2–10	2
A2-61	Motor 2 control mode	0: Sensorless flux vector control (SVC) 1: Closed-loop vector control (FVC) 2: Voltage/Frequency (V/F) control	0
A2-62	Motor 2 acceleration/ deceleration time	0: Same as motor 1 1: Acceleration/Deceleration time 1 2: Acceleration/Deceleration time 2 3: Acceleration/Deceleration time 3 4: Acceleration/Deceleration time 4	0
A2-63	Motor 2 torque boost	0.0%: Automatic torque boost 0.1%–30.0%	Model dependent
A2-65	Motor 2 oscillation suppression gain	0–100	Model dependent

7.18 Group U0 Monitor

C Parameter set is used to monitor the inverter running state information, the customer can see through the Panel, in order to convenient for debugging, also can be read by the communication Parameter set value, to be used for FC monitor. Among them, 31 C - 00 ~ C - is the F7-03 and F7-04 defined in the operation and stop monitoring Parameters. Specific Parameters function code, name and smallest unit see table 6-1

Table 6-1 C Set Parameter table

Function code	Name	Smallest unit	Address
U0-00	Running frequency (Hz)	0.01Hz	7000H
U0-01	Set frequency (Hz)	0.01Hz	7001H
U0-02	Bus voltage (V)	0.1V	7002H

Function code	Name	Smallest unit	Address
U0-03	Output voltage (V)	1V	7003H
U0-04	Output current (A)	0.01A	7004H
U0-05	Output power (kW)	0.1kW	7005H
U0-06	Output torque (%)	0.1%	7006H
U0-07	X state	1	7007H
U0-08	DO state	1	7008H
U0-09	AI1 voltage (V)	0.01V	7009H
U0-10	AI2 voltage (V) / current (mA)	0.01V/0.01mA	700AH
U0-11	AI3 voltage (V)	0.01V	700BH
U0-12	Count value	1	700CH
U0-13	Length value	1	700DH
U0-14	Load speed	1	700EH
U0-15	PID setting	1	700FH
U0-16	PID feedback	1	7010H
U0-17	PLC stage	1	7011H
U0-18	Input pulse frequency (Hz)	0.01kHz	7012H
U0-19	Feedback speed (Hz)	0.01Hz	7013H
U0-20	Remaining running time	0.1Min	7014H
U0-21	AI1 voltage before correction	0.001V	7015H
U0-22	AI2 voltage (V) / current (mA) before correction	0.001V/0.01mA	7016H
U0-23	AI3 voltage before correction	0.001V	7017H
U0-24	Linear speed	1m/Min	7018H
U0-25	Accumulative power-on time	1Min	7019H
U0-26	Accumulative running time	0.1Min	701AH
U0-27	PULSE input frequency	1Hz	701BH
U0-28	Communication setting value	0.01%	701CH
U0-29	Encoder feedback speed	0.01Hz	701DH
U0-30	Main frequency X	0.01Hz	701EH
U0-31	Auxiliary frequency Y	0.01Hz	701FH
U0-32	Viewing any register address value	1	7020H
U0-33	Synchronous motor rotor position	0.1°	7021H
U0-34	Motor temperature	1°C	7022H
U0-35	Target torque (%)	0.1%	7023H
U0-36	Resolver position	1	7024H
U0-37	Power factor angle	0.1°	7025H

Function code	Name	Smallest unit	Address
U0-38	ABZ position	1	7026H
U0-39	Target voltage upon V/F separation	1V	7027H
U0-40	Output voltage upon V/F separation	1V	7028H
U0-41	X state visual display	1	7029H
U0-42	DO state visual display	1	702AH
U0-43	X function state visual display 1 (function 01-40)	1	702BH
U0-44	X function state visual display 2 (function 41- 80)	1	702CH
U0-45	Fault information	1	702DH
U0-58	Phase Z counting	1	703AH
U0-59	Current set frequency (%)	0.01%	703BH
U0-60	Current running frequency (%)	0.01%	703CH
U0-61	AC drive running state	1	703DH
U0-62	Current fault code	1	703EH
U0-63	Reserved	-	703FH
U0-64	Reserved	-	7040H
U0-65	Torque upper limit	0.1%	7041H

8. Parameters

If FP-00 is set to a non-zero number, parameter protection is enabled. You must enter the correct user password to enter the menu.

To cancel the password protection function, enter with password and set FP-00 to 0.

Group F and Group A are standard function parameters. Group U0 includes the monitoring function parameters.

The symbols in the function code table are described as follows:

"☆": The parameter can be modified when the AC drive is in either stop or running state.

"★": The parameter cannot be modified when the AC drive is in the running state.

"●": The parameter is the actually measured value and cannot be modified.

"*": The parameter is factory parameter and can be set only by the manufacturer.

F0 Standard Function Parameters				
Code	Parameter Name	Setting Range	Default	Property
F0-00	Type display	1: HEAVY DUTY 2: NORMAL DUTY	1	●
F0-01	Motor 1 control mode	0: Sensorless flux vector control (SVC) 1: Closed-loop vector control (FVC) 2: Voltage/Frequency (V/F) control	0	★
F0-02	Command source selection	0: Operation Panel control (LED off) 1: Terminal control (LED on) 2: Communication control (LED blinking)	0	☆
F0-03	Main frequency source X selection	0: Digital setup (Preset frequency F0.08, UP/DOWN can be modified, power off without memory) 1 : Digital setup (Preset frequency F0.08, UP/DOWN can be modified, power off with memory) 2 : AI1 3 : AI2 4 : AI3 5 : Pulse setting (X5) 6 : Multi-reference 7 : Simple PLC 8 : PID 9 : Communication	0	★
F0-04	Auxiliary frequency source Y selection	The same as F0-03 (Main frequency source X selection)	0	★

F0 Standard Function Parameters				
Code	Parameter Name	Setting Range	Default	Property
F0-05	Range of auxiliary frequency Y for X and Y operation	0: Relative to maximum frequency 1: Relative to main frequency X	0	☆
F0-06	Range of auxiliary frequency Y for X and Y operation	0% ~ 150%	100%	☆
F0-07	Frequency source selection	Unit's digit (Frequency source selection) 0: Main frequency source X 1: X and Y operation (operation relationship determined by ten's digit) 2: Switchover between X and Y 3: Switchover between X and "X and Y operation" 4: Switchover between Y and "X and Y operation" Ten's digit (X and Y operation relationship) 0: X+Y 1: X-Y 2: Maximum 3: Minimum	00	☆
F0-08	Preset frequency	0.00 to maximum frequency (valid when frequency source is digital setting)	50.00Hz	☆
F0-09	Rotation direction	0: Same direction 1: Reverse direction	0	☆
F0-10	Maximum frequency	50.00Hz ~ 320.00Hz	50.00Hz	★
F0-11	Source of frequency upper limit	0: Set by F0-12 1: AI1 2: AI2 3: AI3 4: Pulse setting 5: Communication setting	0	★
F0-12	Frequency upper limit	Frequency lower limit (F0-14) to maximum frequency (F0-10)	50.00Hz	☆
F0-13	Frequency upper limit offset	0.00 Hz to maximum frequency (F0-10)	0.00Hz	☆
F0-14	Frequency lower limit	0.00 Hz to frequency upper limit (F0-12)	0.00Hz	☆
F0-15	Carrier frequency	0.5kHz ~ 16.0kHz	Model dependent	☆
F0-16	Carrier frequency adjustment with temperature	0: No 1: Yes	1	☆

F0 Standard Function Parameters				
Code	Parameter Name	Setting Range	Default	Property
F0-17	Acceleration time 1	0.00s~650.00s(F0-19=2) 0.0s~6500.0s(F0-19=1) 0 s~65000s(F0-19=0)	Model dependent	☆
F0-18	Deceleration time 1	0.00s~650.00s(F0-19=2) 0.0s~6500.0s(F0-19=1) 0 s~65000s(F0-19=0)	Model dependent	☆
F0-19	Acceleration/Deceleration time unit	0:1s 1: 0.1s 2: 0.01s	1	★
F0-21	Frequency offset of auxiliary frequency source for X and Y	0.00 Hz to maximum frequency F0-10	0.00Hz	☆
F0-22	Frequency reference resolution	1: 0.1Hz 2: 0.01Hz	2	★
F0-23	Retentive of digital setting frequency upon power failure	0: Not retentive 1: Retentive	0	☆
F0-24	Motor parameter group selection	0: Motor parameter group 1 1: Motor parameter group 2 2: Motor parameter group 3 3: Motor parameter group 4	0	★
F0-25	Acceleration/Deceleration time base frequency	0: Maximum frequency (F0-10) 1: Set frequency 2: 100 Hz	0	★
F0-26	Base frequency for UP/DOWN modification during running	0: Running frequency 1: Set frequency	0	★
F0-27	Binding command source to frequency source	Unit's digit (Binding operation panel command to frequency source) 0: No binding 1: Frequency source by digital setting 2: AI1 ; 3: AI2 ; 4: AI3 5: Pulse setting (X 5) 6: Multi-reference 7: Simple PLC; 8: PID 9: Communication setting Ten's digit (Binding terminal command to frequency source) 0-9, same as unit's digit Hundred's digit (Binding communication command to frequency source) 0-9, same as unit's digit	0000	☆
F0-28	Serial communication protocol	0: Modbus protocol	0	☆

F1: Motor 1 Parameters				
Code	Parameter Name	Setting Range	Default	Property
F1-00	Motor type selection	0: Common asynchronous motor 1: Variable frequency asynchronous motor 2: Permanent magnetic synchronous motor	0	★
F1-01	Rated motor power	0.1kW ~ 1000.0kW	Model dependent	★
F1-02	Rated motor voltage	1V ~ 2000V	Model dependent	★
F1-03	Rated motor current	0.01–655.35 A (AC drive power ≤ 55 kW) 0.1–6553.5 A (AC drive power > 55 kW)	Model dependent	★
F1-04	Rated motor frequency	0.01 Hz to maximum frequency	Model dependent	★
F1-05	Rated motor rotational speed	1rpm ~ 65535rpm	Model dependent	★
F1-06	Stator resistance (asynchronous motor)	0.001–65.535 Ω (AC drive power ≤ 55 kW) 0.0001–6.5535 Ω (AC drive power > 55 kW)	Tuned parameters	★
F1-07	Rotor resistance (asynchronous motor)	0.001–65.535 Ω (AC drive power ≤ 55 kW) 0.0001–6.5535 Ω (AC drive power > 55 kW)	Tuned parameters	★
F1-08	Leakage inductive reactance (asynchronous motor)	0.01–655.35 mH (AC drive power ≤ 55 kW) 0.001–65.535 mH (AC drive power > 55 kW)	Tuned parameters	★
F1-09	Mutual inductive reactance (asynchronous motor)	0.1–6553.5 mH (AC drive power ≤ 55 kW) 0.01–655.35 mH (AC drive power > 55 kW)	Tuned parameters	★
F1-10	No-load current (asynchronous motor)	0.01A to F1-03 (AC drive power ≤ 55 kW) 0.1A to F1-03 (AC drive power > 55 kW)	Tuned parameters	★
F1-16	Stator resistance (synchronous motor)	0.001–65.535 Ω (AC drive power ≤ 55 kW) 0.0001–6.5535 Ω (AC drive power > 55 kW)	Tuned parameters	★
F1-17	Shaft D inductance (synchronous motor)	0.01–655.35 mH (AC drive power ≤ 55 kW) 0.001–65.535 mH (AC drive power > 55 kW)	Tuned parameters	★
F1-18	Shaft Q inductance (synchronous motor)	0.01–655.35 mH (AC drive power ≤ 55 kW) 0.001–65.535 mH (AC drive power > 55 kW)	Tuned parameters	★
F1-20	Back EMF (synchronous motor)	0.1V ~ 65535V	Tuned parameters	★
F1-27	Encoder pulses per revolution	1 ~ 65535	1024	★

F1: Motor 1 Parameters				
Code	Parameter Name	Setting Range	Default	Property
F1-28	Encoder type	0: ABZ incremental encoder 1: UVW incremental encoder 2: Resolver 3: SIN/COS encoder 4: Wire-saving UVW encoder	0	★
F1-30	A/B phase sequence of ABZ incremental encoder	0: Forward 1: Reserve	0	★
F1-31	Encoder installation angle	0.0 ~ 359.9°	0.0°	★
F1-32	U, V, W phase sequence of UVW encoder	0: Forward 1: Reverse	0	★
F1-33	UVW encoder angle offset	0.0 ~ 359.9°	0.0°	★
F1-34	Number of pole pairs of resolver	1 ~ 65535	1	★
F1-36	Encoder wire-break fault detection time	0.0s: No action 0.1~10.0s	0.0	★
F1-37	Auto-tuning selection	0: No auto-tuning 1: Asynchronous motor static auto-tuning 2: Asynchronous motor complete auto-tuning 11: Synchronous motor with-load auto-tuning 12: Synchronous motor no-load auto-tuning	0	★

F2 The 1st motor Vector Control Parameters				
Code	Parameter Name	Setting Range	Default	Property
F2-00	Speed loop proportional gain 1	1~100	30	☆
F2-01	Speed loop integral time 1	0.01s~10.00s	0.50s	☆
F2-02	Switchover frequency 1	0.00~F2-05	5.00Hz	☆
F2-03	Speed loop proportional gain 2	1~100	20	☆
F2-04	Speed loop integral time 2	0.01s~10.00s	1.00s	☆
F2-05	Switchover frequency 2	F2-02~Maximum output frequency	10.00Hz	☆
F2-06	Vector control slip gain	50% ~ 200%	100%	☆

F2 The 1st motor Vector Control Parameters				
Code	Parameter Name	Setting Range	Default	Property
F2-07	Time constant of speed loop filter	0.000s ~ 0.100s	0.000s	☆
F2-08	Vector control over excitation gain	0 ~ 200	64	☆
F2-09	Torque upper limit source in speed control mode	0: Function Code F2-10 Setting 1: AI1 2: AI2 3: AI3 4: Pulse setting 5: Communication setting 6: MIN(AI1, AI2) 7: MAX(AI1, AI2) 1-7 option full scale correspond F2-10	0	☆
F2-10	Digital setting of torque upper limit in speed control mode	0.0% ~ 200.0%	150.0%	☆
F2-13	Excitation adjustment proportional	0 ~ 60000	2000	☆
F2-14	Excitation adjustment integral gain	0 ~ 60000	1300	☆
F2-15	Torque adjustment proportional gain	0 ~ 60000	2000	☆
F2-16	Torque adjustment integral gain	0 ~ 60000	1300	☆
F2-17	Speed loop integral property	Unit's digit: integral separation 0: Disabled 1: Enabled	0	☆
F2-18	Field weakening mode of synchronous motor	0: No field weakening 1: Direct calculation 2: Automatic adjustment	1	☆
F2-19	Field weakening depth of synchronous motor	50% ~ 500%	100%	☆
F2-20	Maximum field weakening current	1% ~ 300%	50%	☆
F2-21	Field weakening automatic adjustment gain	10% ~ 500%	100%	☆
F2-22	Field weakening integral multiple	2 ~ 10	2	☆

F3: V/F Control Parameters				
Code	Parameter Name	Setting Range	Default	Property
F3-00	V/F curve setting	0: Linear V/F 1: Multi-point V/F 2: Square V/F 3: 1.2-power V/F 4: 1.4-power V/F 6: 1.6-power V/F 8: 1.8-power V/F 9: Reserved 10: V/F complete separation 11: V/F half separation	0	★
F3-01	Torque boost	0.0% (fixed torque boost) 0.1%–30.0%	Model dependent	☆
F3-02	Cut-off frequency of torque boost	0.00 Hz to maximum output frequency	50.00Hz	★
F3-03	Multi-point V/F frequency 1	0.00Hz~F3-05	0.00Hz	★
F3-04	Multi-point V/F voltage 1	0.0%~100.0%	0.0%	★
F3-05	Multi-point V/F frequency 2	F3-03~F3-07	0.00Hz	★
F3-06	Multi-point V/F voltage 2	0.0%~100.0%	0.0%	★
F3-07	Multi-point V/F frequency 3	F3-05~Motor Rated frequency(F1-	0.00Hz	★
F3-08	Multi-point V/F voltage 3	0.0%~100.0%	0.0%	★
F3-09	V/F slip compensation gain	0.0% ~ 200.0%	0.0%	☆
F3-10	V/F over-excitation gain	0 ~ 200	64	☆
F3-11	V/F oscillation suppression gain	0 ~ 100	Model dependent	☆
F3-13	Voltage source for V/F separation	0: Digital setting (F3-14) 1: AI1 2: AI2 3: AI3 4: Pulse setting (X5) 5: Multi-reference 6: Simple PLC 7: PID 8: Communication setting 100.0% corresponds to the rated motor voltage	0	☆
F3-14	Voltage digital setting for V/F separation	0 V to rated motor voltage	0V	☆

F3: V/F Control Parameters				
Code	Parameter Name	Setting Range	Default	Property
F3-15	Voltage rise time of V/F separation	0.0–1000.0s It indicates the time for the voltage rising from 0 V to rated motor voltage.	0.0s	☆

F4: Input terminal				
Code	Parameter Name	Setting Range	Default	Property
F4-00	X1 function selection	0: No- function 1: Forward command (FWD) 2: Reverse command (REV) 3: Three line running control 4: FWD JOG command(FJOG) 5: REV JOG command(RJOG)	1	★
F4-01	X2 function selection	6: Up command 7: DOWN command 8: IGBT Enable 9: Fault reset(RESET)	2	★
F4-02	X3 function selection	10: Operation suspended 11: External default normally open input 12: Multi-stage speed terminal 1 13: Multi-stage speed terminal 2 14: Multi-stage speed terminal 3 15: Multi-stage speed terminal 4	4	★
F4-03	X4 function selection	16: Acc./dec.time selection terminal 1 17: Acc./dec.time selection terminal 2 18: Frequency source switching 19: UP/DOWN setup reset(terminal and keyboard) 20: Running command switching terminal	9	★
F4-04	X5 function selection	21: Acc./dec forbidden 22: PID pause 23: PLC status reset 24: Swing frequency pause 25: Counter input 26: Counter reset	12	★
F4-05	X6 function selection	27: Length counting input 28: Length counting reset 29: Torque control forbidden 30: PULSE frequency input(Only valid for X5) 31: Reserved	13	★
F4-06	X7 function selection	32: Immediate DC braking 33: External default normally closed input 34: Frequency modification enable 35: PID direction reversed 36: External stop terminal1	0	★

F4: Input terminal				
Code	Parameter Name	Setting Range	Default	Property
F4-07	Reserved	37: Control command switching terminal 2 38: PID integration suspension 39: Frequency source X and preset frequency switching 40: Frequency source Y and preset frequency switching 41: Motor selection terminal 1	0	★
F4-08	Reserved	42: Motor selection terminal 2 43: PID Parameter switching 44: User-defined fault 1 45: User-defined fault 2 46: Speed control/ torque control switching	0	★
F4-09	Reserved	47: Emergency stop 48: External stop terminal 2 49: Deceleration DC braking 50: Running time reset 51-59: Reserved	0	★
F4-10	X filter time	0.000s~1.000s	0.010s	☆
F4-11	Terminal command mode	0: Two-line mode 1 1: Two-line mode 2 2: Three-line mode 1 3: Three-line mode 2	0	★
F4-12	Terminal UP/DOWN rate	0.001Hz/s ~ 65.535Hz/s	1.00Hz/s	☆
F4-13	AI1 curve 1 minimum input	0.00V ~ F4-15	0.00V	☆
F4-14	Corresponding setting of AI1 curve 1 minimum input	-100.0% ~ +100.0%	0.0%	☆
F4-15	AI curve 1 maximum input	F4-13~+10.00V	10.00V	☆
F4-16	Corresponding setting of AI1 curve 1 maximum input	-100.0% ~ +100.0%	100.0%	☆
F4-17	AI1 filter time	0.00s ~ 10.00s	0.10s	☆
F4-18	AI1 curve 2 minimum input	0.00V ~ F4-20	0.00V	☆
F4-19	Corresponding setting of AI1 curve 2 minimum input	-100.0% ~ +100.0%	0.0%	☆
F4-20	AI1 curve 2 maximum input	F4-18 ~ +10.00V	10.00V	☆
F4-21	Corresponding setting of AI1 curve 2 maximum input	-100.0% ~ +100.0%	100.0%	☆

F4: Input terminal				
Code	Parameter Name	Setting Range	Default	Property
F4-22	AI2 filter time	0.00s ~ 10.00s	0.10s	☆
F4-23	AI1 curve 3 minimum input	-10.00V ~ F4-25	-10.00V	☆
F4-24	AI1 Corresponding setting of AI1 curve 3 minimum input	-100.0% ~ +100.0%	-100.0%	☆
F4-25	AI1 curve 3 maximum input	F4-23 ~ +10.00V	10.00V	☆
F4-26	Corresponding setting of AI1 curve 3 maximum input	-100.0% ~ +100.0%	100.0%	☆
F4-27	AI3 filter time	0.00s ~ 10.00s	0.10s	☆
F4-28	PULSE minimum input	0.00kHz ~ F4-30	0.00kHz	☆
F4-29	Corresponding setting of pulse minimum input	-100.0% ~ 100.0%	0.0%	☆
F4-30	PULSE maximum input	F4-28 ~ 100.00kHz	50.00kHz	☆
F4-31	Corresponding setting of pulse maximum input	-100.0% ~ 100.0%	100.0%	☆
F4-32	PULSE filter time	0.00s ~ 10.00s	0.10s	☆
F4-33	AI curve selection	Curve 1 (2 points, see F4-13 to F4-16) Curve 2 (2 points, see F4-18 to F4-21) Curve 3 (2 points, see F4-23 to F4-26) Curve 4 (4 points, see A6-00 to A6-07) Curve 5 (4 points, see A6-08 to A6-15) Ten's digit AI2 curve selection (same as AI1) Hundred's digit AI3 curve selection (same as AI1)	321	☆
F4-34	Setting for AI less than minimum input	Unit's digit (Setting for AI1 less than minimum input) 0: Minimum value 1: 0.0% Ten's digit (Setting for AI2 less than minimum input)0, 1 (same as AI1) Hundred's digit (Setting for AI3 less than minimum input)0, 1 (same as AI1)	000	☆
F4-35	X1 delay time	0.0s ~ 3600.0s	0.0s	★
F4-36	X2 delay time	0.0s ~ 3600.0s	0.0s	★

F4: Input terminal				
Code	Parameter Name	Setting Range	Default	Property
F4-37	X3 delay time	0.0s ~ 3600.0s	0.0s	★
F4-38	X valid mode selection 1	0: High level valid 1: Low level valid Unit's digit: X1 Ten's digit: X2 Hundred's digit: X3 Thousand's digit: X4 Ten thousand's digit: X5	00000	★
F4-39	X valid mode selection 2	0: High level valid 1: Low level valid Unit's digit: X6 Ten's digit: X7 Hundred's digit: X8 Thousand's digit: X9 Ten thousand's digit: X10	00000	★
F4-40	AI2 input signal selection	0: Voltage signal 1: Current signal	0	★

F5: Output Terminals				
Code	Parameter Name	Setting Range	Default	Property
F5-00	DO Terminal output mode	0: Pulse output 1: Switch output	0	☆
F5-01	DO Output function (open collector output terminal)	0: No output; 1: Inverter in operation 2: Output fault(Stop fault) 3: Frequency level detection FDT1 output 4: Frequency arrival 5: Null speed operation(stop without output) 6: Motor overload pre-alarm 7: Inverter overload pre-alarm 8: Setup counting value arrived 9: Designated counting value arrived	0	☆
F5-02	Relay function Selection (1TA-1TB-1TC)	10: Length arrived 11: PLC circulation end 12: Total running time arrived 13: Frequency limit: 14: Torque limit 15: RUN ready ; 16: AI1>AI2 17: Frequency upper limit arrived	2	☆

F5: Output Terminals				
Code	Parameter Name	Setting Range	Default	Property
F5-03	Relay function Selection (2TA-2TB-2TC)	18: Frequency lower limit arrived (stop without output) 19: Under voltage state output 20: Communication setup 21: Brake output 22: MC (magnetic contactor) output 23: Null speed operation 2(Stop with output) 24: Total power-on time arrival 25: Inspection level of FDT2 frequency 26: Frequency 1 arrival output	0	☆
F5-04	Y1 output function selection	27: Frequency 2 arrival output 28: Current 1 arrival output 29: Current 2 arrival output 30: Timing arrival output 31: AI1 excessive input 32: Load off 33: Reverse running 34: Zero current state 35: Module temperature arrival 36: Software excessive current 37: Frequency lower limit arrival(stop with output) 38: Alarm output 39: Motor over temperature alarm	1	☆
F5-05	Reserved	40: The running time arrival 41: Fault output	-	-
F5-06	DO (Pulse) output function selection	0: Running frequency 1: Setup frequency 2: Output current; 3: Output torque 4: Output power;	0	☆
F5-07	AO1 output function selection	5: Output voltage 6: Pulse input (100.0% is 100.0kHz) 7: AI1 ; 8: AI2 9: AI3 (Expansion Card)	0	☆
F5-08	AO2 output function selection	10: Length; 11: Counting value 12: Communication setup 13: Motor revolving speed 14: Output current (100.0% is 1000.0A) 15: Output voltage (100.0% is 1000.0V) 16: Reserved	1	☆

F5: Output Terminals				
Code	Parameter Name	Setting Range	Default	Property
F5-09	Maximum DO(pulse) output frequency	0.01kHz~100.00 kHz	50.00kHz	☆
F5-10	AO1 offset coefficient	-100.00%~+100.00%	0.0%	☆
F5-11	A01gain	-10.00~+10.00	1.00	☆
F5-12	AO2 offset coefficient	-100.00%~+100.00%	0.00%	☆
F5-13	AO2 gain	-10.00~+10.00	1.00	☆
F5-17	DO(switch) output delay time	0.00S~3600.0S	0.0s	☆
F5-18	RELAY1 output delay time	0.00S~3600.0S	0.0s	☆
F5-19	RELAY2output delay time	0.00S~3600.0S	0.0s	☆
F5-20	Y1 output delay time	0.00S~3600.0S	0.0s	☆
F5-21	Reserved	-	-	-
F5-22	DO valid mode selection	0: Positive logic 1: Negative logic Unit's digit: DO(switch) Ten's digit: RELAY1 Hundred's digit: RELAY2 Thousand's digit: Y1	00000	☆

F6:Start/Stop Control				
Code	Parameter Name	Setting Range	Default	Property
F6-00	Start mode	0: Direct start 1: Rotational speed tracking restart 2: Pre-excited start (asynchronous motor)	0	☆
F6-01	Rotational speed tracking mode	0: From frequency at stop 1: From zero speed 2: From maximum frequency	0	★
F6-02	Rotational speed tracking speed	1~100	20	☆
F6-03	Startup frequency	0.00Hz~10.00Hz	0.00Hz	☆
F6-04	Startup frequency holding time	0.0s~100.0s	0.0s	★
F6-05	Startup DC braking current/ Pre-excited current	0%~100%	0%	★
F6-06	Startup DC braking time/ Pre-excited time	0.0s~100.0s	0.0s	★
F6-07	Acceleration/Deceleration mode	0: Linear acceleration/deceleration 1: S-curve acceleration/deceleration A 2: S-curve acceleration/deceleration B	0	★
F6-08	Time proportion of S-curve start segment	0.0%~ (100.0%-F6-09)	30.0%	★

F6:Start/Stop Control				
Code	Parameter Name	Setting Range	Default	Property
F6-09	Time proportion of S-curve end segment	0.0% ~ (100.0%-F6-08)	30.0%	★
F6-10	Stop mode	0: Decelerate to stop 1: Coast to stop	0	☆
F6-11	Initial frequency of stop DC braking	0.00Hz~Maximum frequency	0.00Hz	☆
F6-12	Waiting time of stop DC braking	0.0s~100.0s	0.0s	☆
F6-13	Stop DC braking current	0%~100%	0%	☆
F6-14	Stop DC braking time	0.0s~100.0s	0.0s	☆
F6-15	Stop DC braking time	0%~100%	100%	☆

F7: Operation Panel and Display				
Code	Parameter Name	Setting Range	Default	Property
F7-01	MF Key function selection	0: MF.K key disabled 1: Switchover between operation panel control and remote command control (terminal or communication) 2: Positive & negative switching 3: Forward JOG 4: Reverse JOG	0	★
F7-02	STOP/RESET key function	0: STOP/RESET key enabled only in operation panel control 1: STOP/RESET key enabled in any operation mode	1	☆
F7-03	LED display running parameters 1	0000~FFFF Bit00: Running frequency 1 (Hz) Bit01: Set frequency (Hz) Bit02: Bus voltage (V) Bit03: Output voltage (V) Bit04: Output current (A) Bit05: Output power (kW) Bit06: Output torque (%) Bit07: X input status Bit08: DO output status Bit09: AI1 voltage (V) Bit10: AI2 voltage (V) Bit11: AI3 voltage (V) Bit12: Count value Bit13: Length value Bit14: Load speed display Bit15: PID setting	1F	☆

F7: Operation Panel and Display				
Code	Parameter Name	Setting Range	Default	Property
F7-04	LED display running parameters 2	0000-FFFF Bit00: PID feedback Bit01: PLC stage Bit02: Pulse setting frequency(kHz) Bit03: Running frequency 2 (Hz) Bit04: Remaining running time Bit05: AI1 voltage before correction (V) Bit06: AI2 voltage before correction (V) Bit07: AI3 voltage before correction (V) Bit08: Linear speed Bit09: Current power-on time(Hour) Bit10: Current running time (Min) Bit11: Pulse setting frequency(Hz) Bit12: Communication setting value Bit13: Encoder feedback speed(Hz) Bit14: Main frequency X display(Hz) Bit15: Auxiliary frequency Y display (Hz)	0	☆
F7-05	LED display stop parameters	0000-FFFF Bit00: Set frequency (Hz) Bit01: Bus voltage (V) Bit02: X input status Bit03: DO output status Bit04: AI1 voltage (V) Bit05: AI2 voltage (V) Bit06: AI3 voltage (V) Bit07: Count value Bit08: Length value Bit09: PLC stage Bit10: Load speed Bit11: PID setting Bit12: Pulse setting frequency (kHz)	33	☆
F7-06	Load speed display coefficient	0.0001 ~ 6.5000	1.0000	☆
F7-07	Heatsink temperature of inverter module	0.0℃ ~ 100.0℃	-	●
F7-08	Temporary software version	-	-	●
F7-09	Accumulative running time	0h ~ 65535h	-	●
F7-10	Product number	-	-	●
F7-11	Software version	-	-	●

F7: Operation Panel and Display				
Code	Parameter Name	Setting Range	Default	Property
F7-12	Number of decimal places for load speed display	0: 0 decimal place 1: 1 decimal place 2: 2 decimal places 3: 3 decimal places	1	☆
F7-13	Accumulative power-on time	0 ~ 65535 h	-	●
F7-14	Accumulative power consumption	0 ~ 65535 kwh	-	●

F8: Auxiliary Functions				
Code	Parameter Name	Setting Range	Default	Property
F8-00	JOG running frequency	0.00 Hz to maximum frequency	2.00Hz	☆
F8-01	JOG acceleration time	0.0s ~ 6500.0s	20.0s	☆
F8-02	JOG deceleration time	0.0s ~ 6500.0s	20.0s	☆
F8-03	Acceleration time 2	0.0s ~ 6500.0s	Model dependent	☆
F8-04	Deceleration time 2	0.0s ~ 6500.0s	Model dependent	☆
F8-05	Acceleration time 3	0.0s ~ 6500.0s	Model dependent	☆
F8-06	Deceleration time 3	0.0s ~ 6500.0s	Model dependent	☆
F8-07	Acceleration time 4	0.0s ~ 6500.0s	Model dependent	☆
F8-08	Deceleration time 4	0.0s ~ 6500.0s	Model dependent	☆
F8-09	Jump frequency 1	0.00Hz to maximum frequency	0.00Hz	☆
F8-10	Jump frequency 2	0.00Hz to maximum frequency	0.00Hz	☆
F8-11	Frequency jump amplitude	0.00Hz to maximum frequency	0.01Hz	☆
F8-12	Forward/Reverse rotation dead-zone time	0.0s ~ 3000.0s	0.0s	☆
F8-13	Reverse control	0: Enabled 1: Disabled	0	☆
F8-14	Running mode when set frequency lower than frequency lower limit	0: Run at frequency lower limit 1: Stop 2: Run at zero speed	0	☆
F8-15	Droop control	0.00Hz ~ 10.00Hz	0.00Hz	☆

F8: Auxiliary Functions				
Code	Parameter Name	Setting Range	Default	Property
F8-16	Accumulative power-on time threshold	0h ~ 65000h	0h	☆
F8-17	Accumulative running time threshold	0h ~ 65000h	0h	☆
F8-18	Startup protection	0: No 1: Yes	0	☆
F8-19	Frequency detection value(FDT1)	0.00 Hz to maximum frequency	50.00Hz	☆
F8-20	Frequency detection value(FDT1)	0.0% ~ 100.0% (FDT1 level)	5.0%	☆
F8-21	Detection range of frequency reached	0.0% ~ 100.0% (maximum frequency)	0.0%	☆
F8-22	Jump frequency during acceleration/deceleration	0: Disabled 1: Enabled	0	☆
F8-25	Frequency switchover point between acceleration time 1 and acceleration time 2	0.00 Hz to maximum frequency	0.00Hz	☆
F8-26	Frequency switchover point between deceleration time 1 and deceleration time 2	0.00 to maximum frequency	0.00Hz	☆
F8-27	Terminal JOG preferred	0: Disabled 1: Enabled	0	☆
F8-28	Frequency detection value (PDT2)	0.00 to maximum frequency	50.00Hz	☆
F8-29	Frequency detection hysteresis (PDT2)	0.0% ~ 100.0% (PDT2 level)	5.0%	☆
F8-30	Any frequency reaching detection value 1	0.00 Hz to maximum frequency	50.00Hz	☆
F8-31	Any frequency reaching detection amplitude 1	0.0% ~ 100.0% (maximum frequency)	0.0%	☆
F8-32	Any frequency reaching detection value 2	0.00 Hz to maximum frequency	50.00Hz	☆
F8-33	Any frequency reaching detection amplitude 2	0.0% ~ 100.0% (maximum frequency)	0.0%	☆
F8-34	Zero current detection level	0.0% ~ 300.0% (rated motor current)	5.0%	☆
F8-35	Zero current detection delay time	0.01s ~ 600.00s	0.10s	☆
F8-36	Output over current threshold	0.0% (no detection) 0.1%~300.0% (rated motor current)	200.0%	☆
F8-37	Output over current detection delay time	0.00s ~ 600.00s	0.00s	☆
F8-38	Any current reaching 1	0.0%~300.0% (rated motor current)	100.0%	☆

F8: Auxiliary Functions				
Code	Parameter Name	Setting Range	Default	Property
F8-39	Any current reaching 1 amplitude	0.0%–300.0% (rated motor current)	0.0%	☆
F8-40	Any current reaching 2	0.0%–300.0% (rated motor current)	100.0%	☆
F8-41	Any current reaching 2 amplitude	0.0%–300.0% (rated motor current)	0.0%	☆
F8-42	Timing function	0: Disabled 1: Enabled	0	☆
F8-43	Timing duration source	0: F8-44 1: AI1 2: AI2 3: AI3 (100% of analog input corresponds to the value of F8-44)	0	☆
F8-44	Timing duration	0.0Min ~ 6500.0Min	0.0Min	☆
F8-45	AI1 input voltage lower limit	0.00V ~ F8-46	3.10V	☆
F8-46	AI1 input voltage upper limit	F8-45 ~ 10.00V	6.80V	☆
F8-47	Module temperature threshold	0°C ~ 100°C	75°C	☆
F8-48	Cooling fan control	0: Fan working during running 1: Fan working continuously	0	☆
F8-49	Wakeup frequency	Dormant frequency (F8-51) to maximum frequency (F0-10)	0.00Hz	☆
F8-50	Wakeup delay time	0.0s ~ 6500.0s	0.0s	☆
F8-51	Dormant frequency	0.00 Hz to wakeup frequency (F8-49)	0.00Hz	☆
F8-52	Dormant delay time	0.0s ~ 6500.0s	0.0s	☆
F8-53	Current running time reached	0.0 ~ 6500.0 min	0.0Min	☆
F8-54	Output power correction coefficient	0.00% ~ 200.0%	100.0%	☆

F9: Fault and Protection				
Code	Parameter Name	Setting Range	Default	Property
F9-00	Motor overload protection selection	0: Disabled 1: Enabled	1	☆
F9-01	Motor overload protection gain	0.20~10.00	1.00	☆
F9-02	Motor overload warning coefficient	50%~100%	80%	☆

F9: Fault and Protection				
Code	Parameter Name	Setting Range	Default	Property
F9-03	Overvoltage stall gain	0~100	0	☆
F9-04	Overvoltage stall protective voltage	120%~150%	130%	☆
F9-05	Overcurrent stall gain	0~100	20	☆
F9-06	Overcurrent stall protective Current	100%~200%	170%	☆
F9-07	Short-circuit to ground upon power-on	0: Disabled 1: Enabled	1	☆
F9-09	Fault auto reset times	0 ~ 20	0	☆
F9-10	DO action during fault auto reset	0: Not act 1: Act	0	☆
F9-11	Time interval of fault auto reset	0.1s ~ 100.0s	1.0s	☆
F9-12	Input phase loss protection/ contactor energizing protection selection	Unit's digit: Input phase loss protection Ten's digit: Contactor energizing protection 0: Disabled 1: Enabled	11	☆
F9-13	Output phase loss protection selection	0: Disabled 1: Enabled	1	☆
F9-14	1st fault type	0: No fault 1: Reserved 2: Over-current during acceleration 3: Over-current during deceleration 4: Over-current at constant speed 5: Overvoltage during acceleration 6: Overvoltage during deceleration 7: Overvoltage at constant speed 8: Buffer resistance overload 9: Under voltage 10: AC drive overload 11: Motor overload 12: Power input phase loss 13: Power output phase loss 14: Module overheat 15: External equipment fault 16: Communication fault 17: Contactor fault 18: Current detection fault 19: Motor auto-tuning fault 20: Encoder card fault 21: EEPROM read-write fault 22: AC drive hardware fault 23: Short circuit to ground 24: Reserved 25: Reserved 26: Accumulative running time reached 27: User-defined fault 1 28: User-defined fault 2 29: Accumulative power-on time reached	—	●

F9: Fault and Protection				
Code	Parameter Name	Setting Range	Default	Property
F9-15	2nd fault type		—	•
F9-16	3rd (latest) fault type		—	•
F9-17	Frequency upon 3rd fault	—	—	•
F9-18	Current upon 3rd fault	—	—	•
F9-19	Bus voltage upon 3rd fault	—	—	•
F9-20	X status upon 3rd fault	—	—	•
F9-21	Output terminal status upon 3rd fault	—	—	•
F9-22	AC drive status upon 3rd fault	—	—	•
F9-23	Power-on time upon 3rd fault	—	—	•
F9-24	Running time upon 3rd fault	—	—	•
F9-27	Frequency upon 2nd fault	—	—	•
F9-28	Current upon 2nd fault	—	—	•
F9-29	Bus voltage upon 2nd fault	—	—	•
F9-30	X status upon 2nd fault	—	—	•
F9-31	Output terminal status upon 2nd fault	—	—	•
F9-32	Frequency upon 2nd fault	—	—	•
F9-33	Current upon 2nd fault	—	—	•
F9-34	Bus voltage upon 2nd fault	—	—	•
F9-37	X status upon 1st fault	—	—	•
F9-38	Output terminal status upon 1st fault	—	—	•
F9-39	Frequency upon 1st fault	—	—	•
F9-40	Current upon 1st fault	—	—	•
F9-41	Bus voltage upon 3rd fault	—	—	•
F9-42	X status upon 1st fault	—	—	•
F9-43	Output terminal status upon 1st fault	—	—	•

F9: Fault and Protection				
Code	Parameter Name	Setting Range	Default	Property
F9-44	Frequency upon 1st fault	—	—	●
F9-47	Fault protection action selection 1	Unit's digit (Motor overload, Err1) 0: Coast to stop 1: Stop according to the stop mode 2: Continue to run Ten's digit (Power input phase loss, Err12) Hundred's digit (Power output phase loss, Err13) Thousand's digit (External equipment fault, Err15) Ten thousand's digit (Communication fault, Err16)	00000	☆
F9-48	Fault protection action selection 2	Unit's digit (Encoder fault, Err20) 0: Coast to stop Ten's digit (EEPROM read-write fault, Err21) 0: Coast to stop 1: Stop according to the stop mode Hundred's digit: reserved Thousand's digit (Motor overheat, Err25) Ten thousand's digit (Accumulative running time reached, Err26)	00000	☆
F9-49	Fault protection action selection 3	Unit's digit (User-defined fault 1, Err27) 0: Coast to stop 1: Stop according to the stop mode 2: Continue to run Ten's digit (User-defined fault 2, Err28) 0: Coast to stop 1: Stop according to the stop mode 2: Continue to run Hundred's digit (Accumulative power-on time reached, Err29) 0: Coast to stop 1: Stop according to the stop mode 2: Continue to run Thousand's digit (Load becoming 0, Err30) 1: Coast to stop 2: Continue to run at 7% of rated motor frequency and resume to the set frequency if the load recovers Err31 0: Coast to stop 1: Stop according to the stop mode 2: Continue to run	00000	☆

F9: Fault and Protection				
Code	Parameter Name	Setting Range	Default	Property
F9-50	Fault protection action selection 4	Unit's digit (Too large speed deviation, Err42) 0: Coast to stop 1: Stop according to the stop mode 2: Continue to run Ten's digit (Motor over-speed, Err43) Hundred's digit (Initial position fault, Err51)	00000	☆
F9-54	Frequency selection for continuing to run upon fault	0: Current running frequency 1: Set frequency 2: Frequency upper limit 3: Frequency lower limit 4: Backup frequency upon abnormality	0	☆
F9-55	Backup frequency upon abnormality	0.0% ~ 100.0% (100.0% maximum frequency F0-10)	100.0%	☆
F9-56	Type of motor temperature sensor	0: No temperature sensor 1: PT100 2: PT1000	0	☆
F9-57	Motor overheat protection threshold	0°C ~ 200°C	110°C	☆
F9-58	Motor overheat warning threshold	0°C ~ 200°C	90°C	☆
F9-59	Action selection at instantaneous power failure	0: Invalid 1: Decelerate 2: Decelerate to stop	0	☆
F9-60	Action pause judging voltage at instantaneous power failure	80.0% ~ 100.0%	90.0%	☆
F9-61	Voltage rally judging time at instantaneous power failure	0.00s ~ 100.00s	0.50s	☆
F9-62	Action judging voltage at instantaneous power failure	60.0% ~ 100.0% (standard bus voltage)	80.0%	☆
F9-63	Protection upon load becoming 0	0: Disabled 1: Enabled	0	☆
F9-64	Detection level of load becoming 0	0.0 ~ 100.0%	10.0%	☆
F9-65	Detection time of load becoming 0	0.0 ~ 60.0s	1.0s	☆
F9-67	Over-speed detection value	0.0% ~ 50.0% (maximum frequency)	20.0%	☆
F9-68	Over-speed detection time	0.0s: not detected 0.1 ~ 60.0s	1.0s	☆
F9-69	Detection value of too large speed deviation	0.0% ~ 50.0% (maximum frequency)	20.0%	☆
F9-70	Detection time of too large speed deviation	0.0s: not detected 0.1 ~ 60.0s	5.0s	☆

FA: Process Control PID Function				
Code	Parameter Name	Setting Range	Default	Property
FA-00	PID setting source	0: FA-01 setting 1: AI1 2: AI2 3: AI3 4: PULSE setting (X5) 5: Communication setting 6: Multi-reference	0	☆
FA-01	PID digital setting	0.0% ~ 100.0%	50.0%	☆
FA-02	PID feedback source	0: AI1 1: AI2 2: AI3 3: AI1-AI2 4: PULSE setting (X5) 5: Communication setting 6: AI1+AI2 7: MAX(AI1 , AI2) 8: MIN(AI1 , AI2)	0	☆
FA-03	PID action direction	0: Forward action 1: Reverse action	0	☆
FA-04	PID setting feedback range	0 ~ 65535	1000	☆
FA-05	Proportional gain Kp1	0.0 ~ 100.0	20.0	☆
FA-06	Integral time Ti1	0.01s ~ 10.00s	2.00s	☆
FA-07	Differential time Td1	0.000s ~ 10.000s	0.000s	☆
FA-08	Cut-off frequency of PID reverse rotation	0.00 ~ maximum frequency	2.00Hz	☆
FA-09	PID deviation limit	0.0% ~ 100.0%	0.0%	☆
FA-10	PID differential limit	0.00% ~ 100.00%	0.10%	☆
FA-11	PID setting change time	0.00 ~ 650.00s	0.00s	☆
FA-12	PID feedback filter time	0.00 ~ 60.00s	0.00s	☆
FA-13	PID output filter time	0.00 ~ 60.00s	0.00s	☆
FA-14	Reserved	-	-	☆
FA-15	Proportional gain Kp2	0.0 ~ 100.0	20.0	☆
FA-16	Integral time Ti2	0.01s ~ 10.00s	2.00s	☆

FA: Process Control PID Function				
Code	Parameter Name	Setting Range	Default	Property
FA-17	Differential time Td2	0.000s ~ 10.000s	0.000s	☆
FA-18	PID parameter switchover condition	0: No switchover 1: Switchover via X 2: Automatic switchover based on Deviation	0	☆
FA-19	PID parameter switchover deviation 1	0.0% ~ FA-20	20.0%	☆
FA-20	PID parameter switchover deviation 2	FA-19 ~ 100.0%	80.0%	☆
FA-21	PID initial value	0.0% ~ 100.0%	0.0%	☆
FA-22	PID initial value holding time	0.00 ~ 650.00s	0.00s	☆
FA-23	Maximum deviation between two PID outputs in forward direction	0.00% ~ 100.00%	1.00%	☆
FA-24	Maximum deviation between two PID outputs in reverse direction	0.00% ~ 100.00%	1.00%	☆
FA-25	PID integral property	Unit's digit (Integral separated) 0: Invalid 1: Valid Ten's digit (Whether to stop integral operation when the output reaches the limit) 0: Continue integral operation 1: Stop integral operation	00	☆
FA-26	Detection value of PID feedback loss	0.0%: Not judging feedback loss 0.1% ~ 100.0%	0.0%	☆
FA-27	Detection time of PID feedback loss	0.0s ~ 20.0s	0.0s	☆
FA-28	PID operation at stop	0: No PID operation at stop 1: PID operation at stop	0	☆

FB: Swing Frequency, Fixed Length and Count				
Code	Parameter Name	Setting Range	Default	Property
FB-00	Swing frequency setting mode	0: Relative to the central frequency 1: Relative to the maximum frequency	0	☆
FB-01	Swing frequency amplitude	0.0% ~ 100.0%	0.0%	☆
FB-02	Jump frequency amplitude	0.0% ~ 50.0%	0.0%	☆
FB-03	Swing frequency cycle	0.1s ~ 3000.0s	10.0s	☆
FB-04	Triangular wave rising time coefficient	0.1% ~ 100.0%	50.0%	☆

FB: Swing Frequency, Fixed Length and Count				
Code	Parameter Name	Setting Range	Default	Property
FB-05	Set length	0m ~ 65535m	1000m	☆
FB-06	Actual length	0m ~ 65535m	0m	☆
FB-07	Number of pulses per meter	0.1 ~ 6553.5	100.0	☆
FB-08	Set count value	1 ~ 65535	1000	☆
FB-09	Designated count value	1 ~ 65535	1000	☆

FC: MS speed function&simple PLC function				
Code	Parameter Name	Setting Range	Default	Property
FC-00	Reference 0	-100.0% ~ 100.0%	0.0%	☆
FC-01	Reference 1	-100.0% ~ 100.0%	0.0%	☆
FC-02	Reference 2	-100.0% ~ 100.0%	0.0%	☆
FC-03	Reference 3	-100.0% ~ 100.0%	0.0%	☆
FC-04	Reference 4	-100.0% ~ 100.0%	0.0%	☆
FC-05	Reference 5	-100.0% ~ 100.0%	0.0%	☆
FC-06	Reference 6	-100.0% ~ 100.0%	0.0%	☆
FC-07	Reference 7	-100.0% ~ 100.0%	0.0%	☆
FC-08	Reference 8	-100.0% ~ 100.0%	0.0%	☆
FC-10	Reference 10	-100.0% ~ 100.0%	0.0%	☆
FC-11	Reference 11	-100.0% ~ 100.0%	0.0%	☆
FC-12	Reference 12	-100.0% ~ 100.0%	0.0%	☆
FC-13	Reference 13	-100.0% ~ 100.0%	0.0%	☆
FC-14	Reference 14	-100.0% ~ 100.0%	0.0%	☆
FC-15	Reference 15	-100.0% ~ 100.0%	0.0%	☆
FC-16	Simple PLC running mode	0: Stop after the AC drive runs one cycle 1: Keep final values after the AC drive runs one cycle 2: Repeat after the AC drive runs one cycle	0	☆
FC-17	Simple PLC retentive selection	Unit's digit (Retentive upon power failure) 0: No 1: Yes Ten's digit (Retentive upon stop) 0: No 1: Yes	00	☆
FC-18	Running time of simple PLC reference 0	0.0s(h) ~ 6553.5s(h)	0.0s(h)	☆
FC-19	Acceleration/deceleration time of simple PLC reference 0	0 ~ 3	0	☆

FC: MS speed function&simple PLC function				
Code	Parameter Name	Setting Range	Default	Property
FC-20	Running time of simple PLC reference 1	0.0s(h) ~ 6553.5s(h)	0.0s(h)	☆
FC-21	Acceleration/deceleration time of simple PLC reference 1	0 ~ 3	0	☆
FC-22	Running time of simple PLC reference 2	0.0s(h) ~ 6553.5s(h)	0s(h)	☆
FC-23	Acceleration/deceleration time of simple PLC reference 2	0 ~ 3	0	☆
FC-24	Running time of simple PLC reference 3	0.0s(h) ~ 6553.5s(h)	0.0s(h)	☆
FC-25	Acceleration/deceleration time of simple PLC reference 3	0 ~ 3	0	☆
FC-26	Running time of simple PLC reference 4	0.0s(h) ~ 6553.5s(h)	0.0s(h)	☆
FC-27	Acceleration/deceleration time of simple PLC reference 4	0 ~ 3	0	☆
FC-28	Running time of simple PLC reference 5	0.0s(h) ~ 6553.5s(h)	0.0s(h)	☆
FC-29	Acceleration/deceleration time of simple PLC reference 5	0 ~ 3	0	☆
FC-30	Running time of simple PLC reference 6	0.0s(h) ~ 6553.5s(h)	0.0s(h)	☆
FC-31	Acceleration/deceleration time of simple PLC reference 6	0 ~ 3	0	☆
FC-32	Running time of simple PLC reference 7	0.0s(h) ~ 6553.5s(h)	0.0s(h)	☆
FC-33	Acceleration/deceleration time of simple PLC reference 7	0 ~ 3	0	☆
FC-34	Running time of simple PLC reference 8	0.0s(h) ~ 6553.5s(h)	0.0s(h)	☆
FC-35	Acceleration/deceleration time of simple PLC reference 8	0 ~ 3	0	☆
FC-36	Running time of simple PLC reference 9	0.0s(h) ~ 6553.5s(h)	0.0s(h)	☆
FC-37	Acceleration/deceleration time of simple PLC reference 9	0 ~ 3	0	☆
FC-38	Running time of simple PLC reference 10	0.0s(h) ~ 6553.5s(h)	0.0s(h)	☆
FC-39	Acceleration/deceleration time of simple PLC reference 10	0 ~ 3	0	☆
FC-40	Running time of simple PLC reference 11	0.0s(h) ~ 6553.5s(h)	0.0s(h)	☆
FC-41	Acceleration/deceleration time of simple PLC reference 11	0 ~ 3	0	☆

FC: MS speed function&simple PLC function				
Code	Parameter Name	Setting Range	Default	Property
FC-42	Running time of simple PLC reference 12	0.0s(h) ~ 6553.5s(h)	0.0s(h)	☆
FC-43	Acceleration/deceleration time of simple PLC reference 12	0 ~ 3	0	☆
FC-44	Running time of simple PLC reference 13	0.0s(h) ~ 6553.5s(h)	0.0s(h)	☆
FC-45	Acceleration/deceleration time of simple PLC reference 13	0 ~ 3	0	☆
FC-46	Running time of simple PLC reference 14	0.0s(h) ~ 6553.5s(h)	0.0s(h)	☆
FC-47	Acceleration/deceleration time of simple PLC reference 14	0 ~ 3	0	☆
FC-48	Running time of simple PLC reference 15	0.0s(h) ~ 6553.5s(h)	0.0s(h)	☆
FC-49	Acceleration/deceleration time of simple PLC reference 15	0 ~ 3	0	☆
FC-50	Time unit of simple PLC running	0: s (second) 1: h (hour)	0	☆
FC-51	Reference 0 source	0: Set by FC-00 1: AI1 2: AI2 3: AI3 4: PULSE setting 5: PID 6: Set by preset frequency (F0-08), modified via terminal UP/DOWN	0	☆

PD Communication Parameters				
Code	Parameter Name	Setting Range	Default	Property
FD-00	Baud rate	Unit's digit: MODBUS 0: 300BPS 1: 600BPS 2: 1200BPS 3: 2400BPS 4: 4800BPS 5: 9600BPS 6: 19200BPS 7: 38400BPS 8: 57600BPS 9: 115200BPS	6005	☆

PD Communication Parameters				
Code	Parameter Name	Setting Range	Default	Property
FD-01	MODBUS Data format	0: No check, data format (8-N-2) 1: Even parity check: data format <8,E,1> 2: Odd parity check: data format <8,O,1> 3: No check: data format <8-N-1>	0	☆
FD-02	Local address	0: Broadcast address 1 ~ 247 (Valid for MODBUS)	1	☆
FD-03	MODBUS Response delay	0 ~ 20ms (Valid for MODBUS)	2	☆
FD-04	Communication timeout	0.0: invalid 0.1 ~ 60.0s (Valid for MODBUS)	0.0	☆
FD-05	Modbus protocol selection	Unit's digit: MODBUS 0: Non-standard Modbus protocol 1: Standard Modbus protocol	30	☆
FD-06	Communication reading current resolution	0: 0.01A 1: 0.1A	0	☆

FP Function Code Management				
Code	Parameter Name	Setting Range	Default	Property
FP-00	User password	0~65535	0	☆
FP-01	Restore default settings	0: No operation 01: Restore factory settings except motor parameters 02: Clear records	0	★
FP-02	AC drive parameter display property	Unit's digit (Group U display selection) 0: Not display 1: Display Ten's digit (Group A display selection) 0: Not display 1: Display	11	★

FP Function Code Management				
Code	Parameter Name	Setting Range	Default	Property
FP-03	Individualized parameter display property	Unit's digit (User-defined parameter display selection) 0: Not display 1: Display Ten's digit (User-modified parameter display selection) 0: Not display 1: Display	00	☆
FP-04	Parameter modification property	0: Modifiable 1: Not modifiable	0	☆

A0 Torque Control and Restricting Parameters				
Code	Parameter Name	Setting Range	Default	Property
A0-00	Speed/Torque control selection	0: Speed control 1: Torque control	0	★
A0-01	Torque setting source in torque control	0: Digital setting 1(A0-03) 1: AI1 2: AI2 3: AI3 4: PULSE setting 5: Communication setting 6: MIN(AI1,AI2) 7: MAX(AI1,AI2) Full range of values 1-7 corresponds to the digital setting of A0-03	0	★
A0-03	Torque digital setting in torque control	-200.0% ~ 200.0%	150.0%	☆
A0-05	Forward maximum frequency in torque control	0.00Hz ~ maximum frequency	50.00Hz	☆
A0-06	Reverse maximum frequency in torque control	0.00Hz ~ maximum frequency	50.00Hz	☆
A0-07	Acceleration time in torque control	0.00s ~ 65000s	0.00s	☆
A0-08	Deceleration time in torque control	0.00s ~ 65000s	0.00s	☆

U0: Standard Monitoring Parameters			
Function code	Parameter Name	Min. Unit	Communication Address
U0-00	Running frequency (Hz)	0.01Hz	7000H
U0-01	Set frequency (Hz)	0.01Hz	7001H
U0-02	Bus voltage (V)	0.1V	7002H

U0: Standard Monitoring Parameters			
Function code	Parameter Name	Min. Unit	Communication Address
U0-03	Output voltage (V)	1V	7003H
U0-04	Output current (A)	0.01A	7004H
U0-05	Output power (kW)	0.1kW	7005H
U0-06	Output torque (%)	0.1%	7006H
U0-07	X state	1	7007H
U0-08	DO state	1	7008H
U0-09	AI1 voltage (V)	0.01V	7009H
U0-10	AI2 voltage (V)/ current (mA)	0.01V/0.01mA	700AH
U0-11	AI3 voltage (V)	0.01V	700BH
U0-12	Count value	1	700CH
U0-13	Length value	1	700DH
U0-14	Load speed	1	700EH
U0-15	PID setting	1	700FH
U0-16	PID feedback	1	7010H
U0-17	PLC stage	1	7011H
U0-18	Input pulse frequency (Hz)	0.01kHz	7012H
U0-19	Feedback speed (Hz)	0.01Hz	7013H
U0-20	Remaining running time	0.1Min	7014H
U0-21	AI1 voltage before correction	0.001V	7015H
U0-22	AI2 voltage (V) / current (mA) before correction	0.001V/0.01mA	7016H
U0-23	AI3 voltage before correction	0.001V	7017H
U0-24	Linear speed	1m/Min	7018H
U0-25	Accumulative power-on time	1Min	7019H
U0-26	Accumulative running time	0.1Min	701AH
U0-27	PULSE input frequency	1Hz	701BH
U0-28	Communication setting value	0.01%	701CH
U0-29	Encoder feedback speed	0.01Hz	701DH
U0-30	Main frequency X	0.01Hz	701EH
U0-31	Auxiliary frequency Y	0.01Hz	701FH
U0-32	Viewing any register address value	1	7020H
U0-33	Synchronous motor rotor position	0.1°	7021H

U0: Standard Monitoring Parameters			
Function code	Parameter Name	Min. Unit	Communication Address
U0-34	Motor temperature	1°C	7022H
U0-35	Target torque (%)	0.1%	7023H
U0-36	Resolver position	1	7024H
U0-37	Power factor angle	0.1°	7025H
U0-38	ABZ position	1	7026H
U0-39	Target voltage upon V/F separation	1V	7027H
U0-40	Output voltage upon V/F separation	1V	7028H
U0-41	X state visual display	1	7029H
U0-42	DO state visual display	1	702AH
U0-43	X function state visual display 1 (function 01-40)	1	702BH
U0-44	X function state visual display 2 (function 41- 80)	1	702CH
U0-45	Fault information	1	702DH
U0-58	Phase Z counting	1	703AH
U0-59	Current set frequency (%)	0.01%	703BH
U0-60	Current running frequency (%)	0.01%	703CH
U0-61	AC drive running state	1	703DH
U0-62	Current fault code	1	703EH
U0-63	Reserved	-	703FH
U0-64	Reserved	-	7040H
U0-65	Torque upper limit	0.1%	7041H

9 Maintenance and Troubleshooting

9.1 Routine Repair and Maintenance of the SINUS VEGA

9.1.1 Routine Maintenance

The influence of the ambient temperature, humidity, dust and vibration will cause the aging of the devices in the AC drive, which may cause potential faults or reduce the service life of the AC drive. Therefore, it is necessary to carry out routine and periodic maintenance.

Routine maintenance involves checking:

Whether the motor sounds abnormally during running

Whether the motor vibrates excessively during running

Whether the installation environment of the AC drive changes.

Whether the AC drive's cooling fan works normally

Whether the AC drive overheats

Routine cleaning involves:

Keep the AC drive clean all the time.

Remove the dust, especially metal powder on the surface of the AC drive, to prevent the dust from entering the AC drive.

Clear the oil stain on the cooling fan of the AC drive.

9.1.2 Periodic Inspection

Perform periodic inspection in places where inspection is difficult.

Periodic inspection involves:

Check and clean the air duct periodically.

Check whether the screws become loose.

Check whether the AC drive is corroded.

Check whether the wiring terminals show signs of arcing;

Main circuit insulation test

Prompt: Before measuring the insulating resistance with mega meter (500 VDC mega meter recommended), disconnect the main circuit from the AC drive. Do not use the insulating resistance meter to test the insulation of the control circuit. The high voltage test need not be performed again because it has been completed before delivery.

9.1.3 Replacement of Vulnerable Components

The vulnerable components of the AC drive are cooling fan and filter electrolytic capacitor.

Their service life is related to the operating environment and maintenance status. Generally, the service life is shown as follows:

Component	Service Life	Possible Damage Reason	Judging Criteria
Fan	2 to 3 years	<ul style="list-style-type: none"> • Bearing worn • Blade aging 	<ul style="list-style-type: none"> • Whether there is crack on the blade • Whether there is abnormal vibration noise upon startup
Electrolytic capacitor	4 to 5 years	<ul style="list-style-type: none"> • Input power supply in poor quality • High ambient temperature • Frequent load jumping • Electrolytic aging 	<ul style="list-style-type: none"> • Whether there is liquid leakage. • Whether the safe valve has projected. • Measure the static capacitance. • Measure the insulating resistance.

9.1.4 Storage of the AC Drive

For storage of the AC drive, pay attention to the following two aspects:

- 1) Pack the AC drive with the original packing box provided by HNC Electric.
- 2) Long-term storage degrades the electrolytic capacitor. Thus, the AC drive must be energized once every 2 years, each time lasting at least 5 hours. The input voltage must be increased slowly to the rated value with the regulator.

9.2 Warranty Agreement

- 1) Free warranty only applies to the AC drive itself.
- 2) HNC Electric will provide 18-month warranty (starting from the leave-factory date as indicated on the barcode) for the failure or damage under normal use conditions. If the equipment

has been used for over 18 months, reasonable repair expenses will be charged.

3) Reasonable repair expenses will be charged for the damages due to the following causes:

Improper operation without following the instructions

Fire, flood or abnormal voltage.

Using the AC drive for non-recommended function

4) The maintenance fee is charged according to HNC Electric's uniform standard. If there is an agreement, the agreement prevails.

9.3 Faults and Solutions

The SINUS VEGA provides a total of 24 pieces of fault information and protective functions. After a fault occurs, the AC drive implements the protection function, and displays the fault code on the operation panel (if the operation panel is available).

Before contacting HNC Electric for technical support, you can first determine the fault type, analyze the causes, and perform troubleshooting according to the following tables. If the fault cannot be rectified, contact the agent.

Err22 is the AC drive hardware overcurrent or overvoltage signal. In most situations, hardware overvoltage fault causes Err22.

Fault Name	Display	Possible Causes	Solutions
Inverter unit protection	Err01	1: The output circuit is grounded or short circuited. 2: The connecting cable of the motor is too long. 3: The module overheats. 4: The internal connections become loose. 5: The main control board is faulty. 6: The drive board is faulty.	1: Eliminate external faults. 2: Install a reactor or an output filter. 3: Check the air filter and the cooling fan. 4: Connect all cables properly. 5: Contact the agent. 6: Contact the agent. 7: Contact the agent.
Overcurrent during acceleration	Err02	1: The output circuit is grounded or short circuited. 2: Motor auto-tuning is not performed. 3: The acceleration time is too short. 4: Manual torque boost or V/F curve is not appropriate. 5: The voltage is too low. 6: The startup operation is performed on the rotating motor. 7: A sudden load is added during acceleration. 8: The AC drive model is of too small power class.	1: Eliminate external faults. 2: Perform the motor auto-tuning. 3: Increase the acceleration time. 4: Adjust the manual torque boost or V/F curve. 5: Adjust the voltage to normal range. 6: Select rotational speed tracking restart or start the motor after it stops. 7: Remove the added load. 8: Select an AC drive of higher power class.

Fault Name	Display	Possible Causes	Solutions
Overcurrent during deceleration	Err03	1: The output circuit is grounded or short circuited. 2: Motor auto-tuning is not performed. 3: The deceleration time is too short. 4: The voltage is too low. 5: A sudden load is added during deceleration. 6: The braking unit and braking resistor are not installed.	1: Eliminate external faults. 2: Perform the motor auto-tuning. 3: Increase the deceleration time. 4: Adjust the voltage to normal range. 5: Remove the added load. 6: Install the braking unit and braking resistor.
Overcurrent at constant speed	Err04	1: The output circuit is grounded or short circuited. 2: Motor auto-tuning is not performed. 3: The voltage is too low. 4: A sudden load is added during operation. 5: The AC drive model is of too small power class.	1: Eliminate external faults. 2: Perform the motor auto-tuning. 3: Adjust the voltage to normal range. 4: Remove the added load. 5: Select an AC drive of higher power class.
Overvoltage during acceleration	Err05	1: The input voltage is too high. 2: An external force drives the motor during acceleration. 3: The acceleration time is too short. 4: The braking unit and braking resistor are not installed.	1: Adjust the voltage to normal range. 2: Cancel the external force or install a braking resistor. 3: Increase the acceleration time. 4: Install the braking unit and braking resistor.
Overvoltage during deceleration	Err06	1: The input voltage is too high. 2: An external force drives the motor during deceleration. 3: The deceleration time is too short. 4: The braking unit and braking resistor are not installed.	1: Adjust the voltage to normal range. 2: Cancel the external force or install the braking resistor. 3: Increase the deceleration time. 4: Install the braking unit and braking resistor.
Overvoltage at constant speed	Err07	1: The input voltage is too high. 2: An external force drives the motor during deceleration.	1: Adjust the voltage to normal range. 2: Cancel the external force or install the braking resistor.
Control power supply fault	Err08	The input voltage is not within the allowable range.	Adjust the input voltage to the allowable range.
Under voltage	Err09	1: Instantaneous power failure occurs on the input power supply. 2: The AC drive's input voltage is not within the allowable range. 3: The bus voltage is abnormal. 4: The rectifier bridge and buffer resistor are faulty. 5: The drive board is faulty. 6: The main control board is faulty	1: Reset the fault. 2: Adjust the voltage to normal range. 3: Contact the agent.

Fault Name	Display	Possible Causes	Solutions
AC drive overload	Err10	1: The load is too heavy or locked-rotor occurs on the motor. 2: The AC drive model is of too small power class.	1: Reduce the load and check the motor and mechanical condition. 2: Select an AC drive of higher power class.
Motor overload	Err11	1: F9-01 is set improperly. 2: The load is too heavy or locked-rotor occurs on the motor. 3: The AC drive model is of too small power class.	1: Set F9-01 correctly. 2: Reduce the load and check the motor and the mechanical condition. 3: Select an AC drive of higher power class.
Power input phase loss	Err12	1: The three-phase power input is abnormal. 2: The drive board is faulty. 3: The lightning board is faulty. 4: The main control board is faulty.	1: Eliminate external faults. 2: Contact the agent.
Power output phase loss	Err13	1: The cable connecting the AC drive and the motor is faulty. 2: The AC drive's three-phase outputs are unbalanced when the motor is running. 3: The drive board is faulty. 4: The module is faulty.	1: Eliminate external faults. 2: Check whether the motor three-phase winding is normal. 3: Contact the agent.
Module overheat	Err14	1: The ambient temperature is too high. 2: The air filter is blocked. 3: The fan is damaged. 4: The thermally sensitive resistor of the module is damaged. 5: The inverter module is damaged.	1: Lower the ambient temperature. 2: Clean the air filter. 3: Replace the damaged fan. 4: Replace the damaged thermally sensitive resistor. 5: Replace the inverter module.
External equipment fault	Err15	1: External fault signal is input via X. 2: External fault signal is input via virtual I/O.	Reset the operation.
Communication fault	Err16	1: The host computer is in abnormal state. 2: The communication cable is faulty. 3: F0-28 is set improperly. 4: The communication parameters in group PD are set improperly.	1: Check the cabling of host computer. 2: Check the communication cabling. 3: Set F0-28 correctly. 4: Set the communication parameters properly
Contacting fault	Err17	1: The drive board and power supply are faulty. 2: The contactor is faulty.	1: Replace the faulty drive board or power supply board. 2: Replace the faulty contactor.
Current detection fault	Err18	1: The HALL device is faulty. 2: The drive board is faulty.	1: Replace the faulty HALL device. 2: Replace the faulty drive board.
Motor auto-tuning fault	Err19	1: The motor parameters are not set according to the nameplate. 2: The motor auto-tuning times out.	1: Set the motor parameters according to the nameplate properly. 2: Check the cable connecting the AC drive and the motor.

Fault Name	Display	Possible Causes	Solutions
Encoder fault	Err20	1: The encoder type is incorrect. 2: The cable connection of the encoder is incorrect. 3: The encoder is damaged. 4: The encoder card is faulty.	1: Set the encoder type correctly based on the actual situation. 2: Eliminate external faults. 3: Replace the damaged encoder. 4: Replace the faulty encoder card.
EEPROM read-write fault	Err21	The EEPROM chip is damaged.	Replace the main control board
AC drive hardware fault	Err22	1: Overvoltage exists. 2: Overcurrent exists.	1: Handle based on overvoltage. 2: Handle based on overcurrent.
Short circuit to ground	Err23	The motor is short circuited to the ground.	Replace the cable or motor.
Accumulative running time reached	Err26	The accumulative running time reaches the setting value.	Clear the record through the parameter initialization function
User-defined fault 1	Err27	1: The user-defined fault 1 signal is input via X. 2: User-defined fault 1 signal is input via virtual I/O.	Reset the operation.
User-defined fault 2	Err28	1: The user-defined fault 2 signal is input via X. 2: The user-defined fault 2 signal is input via virtual I/O.	Reset the operation.
Accumulative power-on time reached	Err29	The accumulative power-on time reaches the setting value.	Clear the record through the parameter initialization function
Load becoming 0	Err30	The AC drive running current is lower than F9-64.	Check that the load is disconnected or the setting of F9-64 and F9-65 is correct.
PID feedback lost during running	Err31	The PID feedback is lower than the setting of FA-26.	Check the PID feedback signal or set FA-26 to a proper value.
Pulse-by-pulse current limit fault	Err40	1: The load is too heavy or locked-rotor occurs on the motor. 2: The AC drive model is of too small power class.	1: Reduce the load and check the motor and mechanical condition. 2: Select an AC drive of higher power class.
Motor switchover fault during running	Err41	Change the selection of the motor via terminal during running of the AC drive.	Perform motor switchover after the AC drive stops.
Too large speed deviation	Err42	1: The encoder parameters are set incorrectly. 2: The motor auto-tuning is not performed. 3: F9-69 and F9-70 are set incorrectly.	1: Set the encoder parameters properly. 2: Perform the motor auto-tuning. 3: Set F9-69 and F9-70 correctly based on the actual situation.
Motor over-speed	Err43	1: The encoder parameters are set incorrectly. 2: The motor auto-tuning is not performed.3: F9-69 and F9-70 are set incorrectly.	1: Set the encoder parameters properly. 2: Perform the motor auto-tuning. 3: Set F9-69 and F9-70 correctly based on the actual situation.

Fault Name	Display	Possible Causes	Solutions
Motor overheat	Err45	1: The cabling of the temperature sensor becomes loose. 2: The motor temperature is too high.	1: Check the temperature sensor cabling and eliminate the cabling fault. 2: Lower the carrier frequency or adopt other heat radiation measures.
Initial position fault	Err51	The motor parameters are not set based on the actual situation.	Check that the motor parameters are set correctly and whether the setting of rated current is too small.

9.4 Common Faults and Solutions

You may come across the following faults during the use of the AC drive. Refer to the following table for simple fault analysis.

Table 7-2 Troubleshooting to common faults of the AC drive

SN	Fault	Possible Causes	Solutions
1	There is no display at power-on.	1: There is no power supply to the AC drive or the power input to the AC drive is too low. 2: The power supply of the switch on the drive board of the AC drive is faulty. 3: The rectifier bridge is damaged. 4: The control board or the operation panel is faulty. 5: The cable connecting the control board and the drive board and the operation panel breaks.	1: Check the power supply. 2: Check the bus voltage. 3: Re-connect the 8-core and 28-core cables. 4: Contact the agent for technical support.
2	"nF" is displayed at power-on.	1: The cable between the drive board and the control board is in poor contact. 2: Related components on the control board are damaged. 3: The motor or the motor cable is short circuited to the ground. 4: The HALL device is faulty. 5: The power input to the AC drive is too low.	1: Re-connect the 8-core and 28-core cables. 2: Contact the agent for technical support.
3	"Err23" is displayed at power-on.	1: The motor or the motor output cable is short-circuited to the ground. 2: The AC drive is damaged.	1: Measure the insulation of the motor and the output cable with a megger. 2: Contact the agent for technical support.

SN	Fault	Possible Causes	Solutions
4	The AC drive display is normal upon power-on. But “nF” is displayed after running and stops immediately.	1: The cooling fan is damaged or locked-rotor occurs. 2: The external control terminal cable is short circuited.	1: Replace the damaged fan. 2: Eliminate external fault.
5	Err14 (module overheat) fault is reported frequently.	1: The setting of carrier frequency is too high. 2: The cooling fan is damaged, or the air filter is blocked. 3: Components inside the AC drive are damaged (thermal coupler or others).	1: Reduce the carrier frequency (F0-15). 2: Replace the fan and clean the air filter. 3: Contact the agent for technical support.
6	The motor does not rotate after the AC drive runs.	1: Check the motor and the motor cables. 2: The AC drive parameters are set improperly (motor parameters). 3: The cable between the drive board and the control board is in poor contact. 4: The drive board is faulty.	1: Ensure the cable between the AC drive and the motor is normal. 2: Replace the motor or clear mechanical faults. 3: Check and re-set motor parameters.
7	The X terminals are disabled.	1: The parameters are set incorrectly. 2: The external signal is incorrect. 3: The jumper bar across PLC and +24 V becomes loose. 4: The control board is faulty.	1: Check and reset the parameters in group P4. 2: Re-connect the external signal cables. 3: Re-confirm the jumper bar across PLC and +24 V. 4: Contact the agent for technical support.
8	The motor speed is always low in FVC mode.	1: The encoder is faulty. 2: The encoder cable is connected incorrectly or in poor contact. 3: The encoder card is faulty. 4: The drive board is faulty.	1: Replace the encoder and ensure the cabling is proper. 2: Replace the encoder card. 3: Contact the agent for technical support.
9	The AC drive reports overcurrent and overvoltage frequently.	1: The motor parameters are set improperly. 2: The acceleration/deceleration time is improper. 3: The load fluctuates.	1: Re-set motor parameters or re-perform the motor auto-tuning. 2: Set proper acceleration/deceleration time. 3: Contact the agent for technical support.

SN	Fault	Possible Causes	Solutions
10	Err17 is reported upon power-on or running.	The soft startup contactor is not picked up.	1: Check whether the contactor cable is loose. 2: Check whether the contactor is faulty. 3: Check whether 24 V power supply of the contactor is faulty. 4: Contact the agent for technical support.
11	EEEE is displayed upon power-on.	Related component on the control board is damaged.	Replace the control board.

10 Modbus communication

SINUS VEGA series inverter provides the RS485 communication interface, and support the Modbus RTU - from standing communication protocol. Users can through the computer or PLC central control, through the communication protocol Setting frequency converter running commands, modify or read function code parameters, read the inverter working condition and fault information, etc.

1. Protocol content

The entire message frame must be used as a continuous stream. If the pause time frame prior to the completion of more than 1.5 byte times, the receiving device will refresh the incomplete message and assumes that the next byte will be the address field of a new message. Similarly, if a new message starts in less than 3.5 bytes times following the previous message, the receiving device will consider it a continuation of the previous message. This will set an error, as the value in the final CRC field will not be valid for the combined messages. A typical message frame is shown below.

Application mode:

The inverter accessing with “single main multi-slave” PC/PLC control network, which equipped with RS232/RS485 bus.

Bus structure:

(1)Interface mode

RS232/RS485 hardware interface

(2)Transmission mode

Asynchronous serial, half-duplex transmission. At the same time host and slave computer can only permit one to send data while the other can only receive data. Data in the process of serial asynchronous communication is in the message format and sent one frame by one frame.

(3)Topological mode

In single-master system, the setup range of slave address is 1 to 247. Zero refers to broadcast communication address. The address of slave must be exclusive in the network. That is one condition of one slave machine.

Communication information structure

SINUS VEGA Modbus protocol communication data format is as below:

Including: starting bit, 8 data bits, parity bit and stop bit.

Starting bit	Bit1	Bit2	Bit3	Bit4	Bit5	Bit6	Bit7	Bit8	Parity bit	Stop bit
--------------	------	------	------	------	------	------	------	------	------------	----------

The entire message frame must be used as a continuous stream. If the pause time frame prior to the completion of more than 1.5 byte times, the receiving device will refresh the incomplete message and assumes that the next byte will be the address field of a new message. Similarly, if a new message starts in less than 3.5 bytes times following the previous message, the receiving device will consider it a continuation of the previous message. This will set an error, as the value in the final CRC field will not be valid for the combined messages. A typical message frame is shown below.

RTU frame format:

START	3.5-character time
Slave address ADDR	Communication address: 1~247
Command code CMD	03H: Read slave parameters; 06H: Write slave parameters 08H: Loop since detection
DATA	Function code parameter address, function code parameter number, function code parameter value, etc.
CRC CHK low order	Detection value: CRC value
CRC CHK high order	
END	At least 3.5-character time

In the RTU mode, a new frame to at least 3.5 bytes transmission time interval as a start. And then transfer the data fields in the order: from the machine address, operation command code, data and CRC check words, each domain bytes are hex 0... 9, A. F. Continuously detect network bus network facilities, including pause interval of time. When receiving the first field (address information), each network device to decrypt the byte to determine whether to own. A byte at the end of transmission is complete, and with a 3.5 bytes of transmission time interval at least to indicate the end of the frame, in the later, can start a new message.

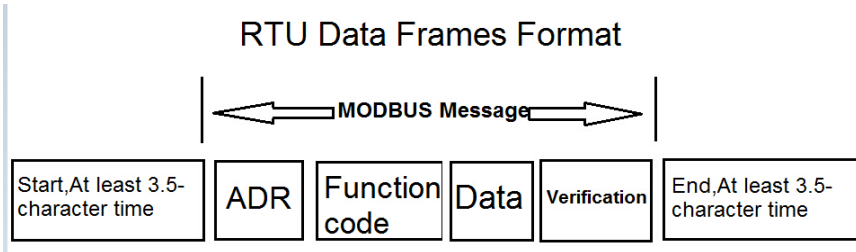

Command code and communication data description

Command code: 03H, read N (Word), maximum continuously read 12 words.

For example the inverter start address F0-02 of the slave machine address 01 continuously reads two consecutive values.

RTU Host Commands:

ADR	01H
CMD	03H
Start address high order	F0H
Start address low order	02H
Register number high order	00H
Register number low order	02H
CRC CHK low order	CRC CHK values to be calculated
CRC CHK high order	

RTU slave response

FD-05 set “0”:

ADR	01H
CMD	03H
Byte number high order	00H
Byte number low order	04H
Data P002H high order	00H
Data P002H low order	00H
Data P003H high order	00H
CRC CHK low order	01H
CRC CHK high order	CRC CHK values to be calculated
CRC CHK low order	

FD-05 set “1”:

ADR	01H
CMD	03H
Byte number	04H
Data F002H high order	00H
Data F002H low order	00H
Data F003H high order	00H
Data F003H low order	01H
CRC CHK low order	CRC CHK values to be calculated
CRC CHK high order	

Command code: 06H write a word

For example: Write 5000 (1388H) into F00AH which slave address is 02H.

RTU host commands

ADR	02H
CMD	06H
Data address high order	F0H
Data address low order	0AH
Data content high order	13H
Data content low order	88H
CRC CHK low order	CRC CHK values to be calculated
CRC CHK high order	

RTU slave response

ADR	01H
CMD	06H
Data address high order	F0H
Data address low order	0AH
Data content high order	13H
Data content low order	88H
CRC CHK low order	CRC CHK values to be calculated
CRC CHK high order	

Cyclical Redundancy Check:

Cyclical Redundancy Check—CRC mode: CRC(Cyclical Redundancy Check) is in RTU frame format, message contains an error-checking field that is based on a CRC method. The CRC field checks the contents of the entire message. The CRC field is two bytes, containing a 16-bit binary value. The CRC value is calculated by the transmitting device, which appends the CRC to the message. The receiving device recalculates a CRC during receipt of the message, and

compares the calculated value to the actual value it received in the CRC field. If the two values are not equal, then results an error. The CRC is started by 0xFFFF. Then a process begins of applying successive 8-bit bytes of the message to the current contents of the register. Only the eight bits of data in each character are used for generating the CRC. Start and stop bits, and the parity bit, do not apply to the CRC.

During generation of the CRC, each eight-bit character is exclusive XOR with the register contents. Then the result is shifted in the direction of the least significant bit (LSB), with a ZERO filled into the most significant bit (MSB) position. The LSB extracted and examined. If the LSB is 1, the register then exclusive XOR with a preset, fixed value. If the LSB is 0, no exclusive XOR takes place. This process is repeated until 8 shifts have been performed. After the last (8) shift, the next eight-bit byte is exclusive XOR with the register's current value, and the process repeats for 8 more shifts as described above. The final contents of the register, after all the bytes of the message have been applied, is the CRC value.

When CRC appended to the message, the low byte is appended first, and then the high byte.

CRC calculation program:

```
unsigned int crc_chk_value(unsigned char *data_value,unsigned char length)
{
unsigned int crc_value=0xFFFF;
int i;
while(length--)
{
crc_value^=*data_value++;
for(i=0;i<8;i++)
{
if(crc_value&0x0001)
{
crc_value=(crc_value>>1)^0xa001;
```

```
}  
  
else  
  
{  
  
crc_value=crc_value>>1;  
  
}  
  
}  
  
}  
  
return(crc_value);  
  
}
```

Communication data address definition:

The chapter is about communication contents, it's used to control the inverter operation, the status of the inverter and related parameter setup. Read and write function code parameters (Some function codes are not able to be changed, only for the manufacturer use.). The mark rules of function code parameters address:

The group number and mark of function codes are parameter address for indication rules.

High byte: F0~FF (F group), A0~AF (A group), 70~7F (U group) Low byte: 00~FF

For example: F3-12, the address indicates 0xF30C

Caution:

Group FF: Parameters could not be read or be modified.

Group U: Parameters could be read but not be modified.

Some parameters can not be changed during operation; some parameters regardless of the kind of state the inverter in, the parameters can not be changed. Change the function code parameters, pay attention to the scope of the parameters, units, and relative instructions.

Besides, if EEPROM is frequently stored, it will reduce the service life of EEPROM. In some communication mode, function code needn't to be stored as long as changing the RAM value.

Group F: to achieve this function, change high order F of the function code address into 0.

Group A: to achieve this function, change high order A of the function code address to be 4.

Corresponding function code addresses are indicated below:

High byte: 00~0F (F group), 40~4F (A group) Low byte: 00~FF

For example:

Function code F3-12 can not be stored into EEPROM, address indicates to be 030C, function code A0-05 can not be stored in EEPROM, address indicates to be 4005; This address can only act writing RAM, it can not act reading, when act reading, it is invalid address. For all parameters, command code 07H can be used to achieve this function.

Stop/run parameters:

Parameter add.	Parameter description	Parameter addr.	Parameter description
1000H	* Communication Setting value (decimalism) -10000 ~ 10000	1010H	PID setup
1001H	Running frequency	1011H	PID feedback
1002H	Bus voltage	1012H	PLC process
1003H	Output voltage	1013H	PULSE input pulse frequency, unit 0.01kHz
1004H	Output current	1014H	Feedback speed, unit 0.1Hz
1005H	Output power	1015H	Rest running time
1006H	Output torque	1016H	AI1 voltage before correction
1007H	Running speed	1017H	AI2 voltage before correction
1008H	X input status	1018H	AI3 voltage before correction
1009H	DO output status	1019H	Line speed
100AH	AI1 voltage	101AH	Current power on time
100BH	AI2 voltage	101BH	Current running time
100CH	Running speed	101CH	PULSE input pulse frequency, unit 1Hz

Parameter addr.	Parameter description	Parameter addr.	Parameter description
100DH	X input status	101DH	Communication setup value
100EH	DO output status	101EH	Actual feedback speed
100FH	A11 voltage	101FH	Main frequency X display
–	–	1020H	Auxiliary frequency Y display

Caution:

The communication setup value is percentage of the relative value, 10000 corresponds to 100.00%, -10000 corresponds to -100.00%. For data of dimensional frequency, the percentage value is the percentage of the maximum frequency. For data of dimensional torque, the percentage is F2-10, A2.48, A3.48, A4.48 (Torque upper digital setup, corresponding to the first, second, third, fourth motor).

Control command input to the inverter (write-only)

Command word address	Command function
2000H	0001: Forward operation
	0002: Reverse operation
	0003: Forward jog
	0004: Reverse jog
	0005: Free stop
	0006: Speed-down stop
	0007: Fault reset

Read inverter status: (read-only)

Status word address	Status word function
3000H	0001: Forward operation
	0002: Reverse operation
	0003: Stop

Parameters lock password check: (if the return is the 8888H, it indicates the password checksum pass)

Password address	Contents of input password
1F00H	*****

Digital output terminal control: (write-only)

Command address	Command content
2001H	BIT0: Y1 Output Control BIT1: - BIT2: RELAY1 output control BIT3: RELAY2 output control BIT4: DO(switch) output control BIT5: VY1 BIT6: VDO2 BIT7: VDO3 BIT8: VDO4 BIT9: VDO5

Analog output AO1 control: (write-only)

Command address	Command content
2002H	0 ~ 7FFF means 0% ~ 100%

Analog output AO2 control: (write-only)

Command address	Command content
2003H	0 ~ 7FFF means 0% ~ 100%

(PULSE) output control: (write-only)

Command address	Command content
2004H	0 ~ 7FFF means 0% ~ 100%

Inverter fault description:

Inverter fault address	Inverter fault information	
8000H	0000: No fault	0015: Parameter read and write fault
	0001: Reserved	0016: Inverter hardware fault
	0002: Speed-up over current	0017: Motor earthing short-circuit fault
	0003: Speed-down over current	0018: Reserved
	0004: Constant speed over current	0019: Reserved
	0005: Speed-up over voltage	001A: Running time arrive fault
	0006: Speed-down over voltage	001B: User defined fault 1
	0007: Constant speed over voltage	001C: User defined fault 2
	0008: Buffer resistance overload fault	001D: Power on time arrive fault
	0009: Under-voltage fault	001E: Load off
	000A: Inverter overload	001F: PID feedback lost during operation
	000B: Motor overload	0028: Fast current limit timeout fault
	000C: Input phase lost	0029: Motor shifting fault during operation
	000D: Output phase lost	002A: Excessive speed deviation
	000E: Module overheating	002B: Motor over speed
000F: External fault	002D: Motor over-temperature	
0010: Communication fault	005A: Encoder line number setup fault	
0011: Contactor fault	005B: Encoder not connected	
0012: Current detection fault	005C: Initial position error	
0013: Motor tuning fault	005E: Speed feedback fault	
0014: Encoder card fault		

Pd group communication parameters description

FD-00	Baud rate	Default	6005
	Setting range	Digital's bit: MODBUS Baud rate	
	0: 300BPS	5: 9600BPS	
	1: 600BPS	6: 19200BPS	
	2: 1200BPS	7: 38400BPS	
	3: 2400BPS	8: 57600BPS	
	4: 4800BPS	9: 115200BPS	

This parameter is used to set the data transfer rate between the host computer and the inverter.

Caution: The baud rate of the position machine and the inverter must be consistent.

Or, communication is impossible. The higher the baud rate is, the faster the communication is.

FD-01	Data format	Default	0
	Setting range	0: No check: data format <8,N,2> 1: Even parity check: data format <8,E,1> 2: Odd parity check: data format <8,O,1> 3: No check: data format <8-N,1>	

The data format of the position machine and the inverter setup must be consistent, otherwise communication is impossible.

FD-02	Local address	Default	1
	Setting range	1~247, 0 is broadcast address.	

When the local address is set to 0, that is the broadcast address, achieve position machine's broadcast function. The local address is unique (except for the broadcast address), which is the basis for the position machine and the inverter point to point communication.

FD-03	Response delay	Default	2ms
	Setting range	0~20ms	

Response delay: It refers to the interval time from the inverter finishes receiving data to sending data to the position machine. If the responses delay is less than the system processing time, the response based on the time delay of the system processing time. If the response delay is more than the system processing time, after the system process the data, it should be delayed to wait until the response delay time is up, then sending data to host machine.

FD-04	Communication overtime	Default	0.0 s
	Setting range	0.0 s (invalid); 0.1~60.0s	

When the function set to 0.0s, the communication overtime parameter is invalid.

When the function code is set to valid value, if the interval time between one communication with the next communication exceeded the communications overtime, the system will report communication fault error (Err16) . Under normal circumstances, it will be set to invalid value. If the system of continuous communication, setting parameters, you can monitor the communication status.

FD-05	Communication protocol selection	Default	0
	Setting range	0: non standard Modbus protocol 1: Standard Modbus Protocol	

FD-05=1: Select Standard Modbus protocol.

FD-05=0: Reading command, the slave returns the number of bytes which has one more byte than the standard Modbus protocol, for specific please refer to the protocol, the part of the "5 communication data structure".

FD-06	Communication read the current resolution	Default	0
	Setting range	0: 0.01A; 1: 0.1A	

To determine when the communication reads the output current, what the output current value unit is.



Via Della Concia, 7
40023 Castel Guelfo (BO)-ITALY
t. +39 0542 489711 - f. +390542 489722
info@santerno.com - santerno.com

